

Report
on

“2181” ALU PROJECT

designed for

Rafic M. Makki, Ph.D.

*Department of Electrical and Computer Engineering Science
The University of North Carolina at Charlotte*

designed by

Paolo Batoni

*ECGR 2181 - Section 001
Logic System Design I*

December 5th, 2001

TABLE OF CONTENTS

LIST OF FIGURES AND TABLES	iv
PREFACE	vi
INTRODUCTION	1
“2181” ALU CIRCUIT DIAGRAM	3
FUNCTION A + B: Block Diagram	4
FUNCTION A + B: Modulus Schematics	5
FUNCTION A + B: Modulus Circuit	6
FUNCTION A - B: Block Diagram	7
FUNCTION A - B: Modulus Schematics	8
FUNCTION A - B: Modulus Circuit	9
FUNCTION $A \oplus B$: Block Diagram	10
FUNCTION $A \oplus B$: Modulus Schematics	11
FUNCTION $A \oplus B$: Modulus Schematics	12
FUNCTION A' : Block Diagram	13
FUNCTION A' : Modulus Schematics	14
FUNCTION A' : Modulus Circuit	15
FUNCTION B' : Block Diagram	16
FUNCTION B' : Modulus Schematics	17
FUNCTION B' : Modulus Circuit	18
FUNCTION 0001: Modulus Schematics	19
FUNCTION 0001: Modulus Circuit	20
FUNCTION 2'S of A' : Block Diagram	21
FUNCTION 2'S of A' : Modulus Schematics	22
FUNCTION 2'S of A' : Modulus Circuit	23
FUNCTION A NAND B: Block Diagram	24
FUNCTION A NAND B: Modulus Schematics	25
FUNCTION A NAND B: Modulus Circuit	26
FUNCTION G: Modulus Schematics	27
FUNCTION G: Modulus Circuit	28
FUNCTION E: Modulus Schematics	29

FUNCTION E: Modulus Circuit	30
8-to1 MUX: Modulus Schematics	31
8-to1 MUX: Modulus Circuit	32
SIMULATION STRATEGY	33
“2181” ALU PROJECT: Simulation 1/8	34
“2181” ALU PROJECT: Simulation 2/8	35
“2181” ALU PROJECT: Simulation 3/8	36
“2181” ALU PROJECT: Simulation 4/8	37
“2181” ALU PROJECT: Simulation 5/8	38
“2181” ALU PROJECT: Simulation 6/8	39
“2181” ALU PROJECT: Simulation 7/8	40
“2181” ALU PROJECT: Simulation 8/8	41
CONCLUSIONS	42

LIST OF FIGURES AND TABLES

TABLE 1.	Functions and Outputs	2
FIGURE 1.	General Schematics of the “2181” ALU	1
FIGURE 2.	Detailed Schematics of the “2181” ALU	2
FIGURE 3.	Mentor Graphics: Schematics of the “2181” ALU	3
FIGURE 4:	Function $A + B$: Block Diagram	4
FIGURE 5:	Function $A + B$: Modulus Schematics	5
FIGURE 6:	Function $A + B$: Modulus Circuit	6
FIGURE 7:	Function $A - B$: Block Diagram	7
FIGURE 8:	Function $A - B$: Modulus Schematics	8
FIGURE 9:	Function $A - B$: Modulus Circuit	9
FIGURE 10:	Function $A \oplus B$: Block Diagram	10
FIGURE 11:	Function $A \oplus B$: Modulus Schematics	11
FIGURE 12:	Function $A \oplus B$: Modulus Schematics	12
FIGURE 13:	Function A' : Block Diagram	13
FIGURE 14:	Function A' : Modulus Schematics	14
FIGURE 15:	Function A' : Modulus Circuit	15
FIGURE 16:	Function B' : Block Diagram	16
FIGURE 17:	Function B' : Modulus Schematics	17
FIGURE 18:	Function B' : Modulus Circuit	18
FIGURE 19:	Function 0001: Modulus Schematics	19
FIGURE 20:	Function 0001: Modulus Circuit	20
FIGURE 21:	Function $2'S$ of A : Block Diagram	21
FIGURE 22:	Function $2'S$ of A : Modulus Schematics	22
FIGURE 23:	Function $2'S$ of A : Modulus Circuit	23
FIGURE 24:	Function $A \text{ NAND } B$: Block Diagram	24
FIGURE 25:	Function $A \text{ NAND } B$: Modulus Schematics	25
FIGURE 26:	Function $A \text{ NAND } B$: Modulus Circuit	26
FIGURE 27:	Function G : Modulus Schematics	27
FIGURE 28:	Function G : Modulus Circuit	28
FIGURE 29:	Function E : Modulus Schematics	29

FIGURE 30: Function E: Modulus Circuit	30
FIGURE 31: 8-TO-1 Multiplexor: Modulus Circuit	31
FIGURE 32: 8-TO-1 Multiplexor: Modulus Circuit	32
FIGURE 33: "2181" ALU PROJECT: Simulation 1/8	34
FIGURE 34: "2181" ALU PROJECT: Simulation 2/8	35
FIGURE 35: "2181" ALU PROJECT: Simulation 3/8	36
FIGURE 36: "2181" ALU PROJECT: Simulation 4/8	37
FIGURE 37: "2181" ALU PROJECT: Simulation 5/8	38
FIGURE 38: "2181" ALU PROJECT: Simulation 6/8	39
FIGURE 41: "2181" ALU PROJECT: Simulation 7/8	40
FIGURE 42: "2181" ALU PROJECT: Simulation 8/8	41

PREFACE

It was a responsibility of Paolo Batoni to design an Arithmetic Logic Unit (ALU) with three A inputs, three B inputs, three S inputs, four D outputs, one G output, and one E output, by solely using what was learned during the length of the Logic System Design I taught by Rafic M. Makki, PhD, at the Department of Electrical and Computer Engineering Science of the University of North Carolina at Charlotte.

Report
on
“2181” ALU PROJECT

INTRODUCTION

Paolo Batoni was requested to design an Arithmetic Logic Unit (ALU) with three A inputs, three B inputs, three S inputs, four D outputs, one G output, and one E output, by solely using what was learned during the length of the Logic System Design I taught by Rafic M. Makki, PhD, at the Department of Electrical and Computer Engineering Science of the University of North Carolina at Charlotte.

For a better visualization of the goal of the project, the general schematics of the above-mentioned ALU was shown in Figure 1, while the operations processed by the logic circuit were enlisted in Table 1.

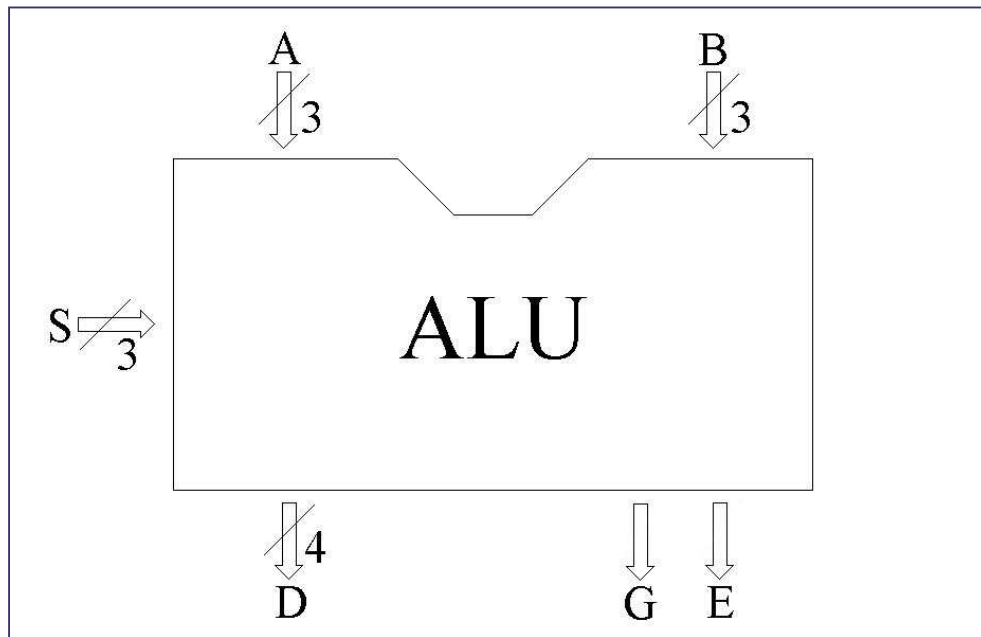

Figure 1: General Schematics of the “2181” ALU

Table 1 Functions and Outputs										
S ₂	S ₁	S ₀	Input		Function	Output	Function	Output	Function	Output
0	0	0	A	B	A + B	D	A > B	G	A = B	E
0	0	1			A - B					
0	1	0			A ⊕ B					
0	1	1			A'					
1	0	0			B'					
1	0	1			0001					
1	1	0			2'S of A					
1	1	1			A NAND B					

For a better comprehension of how the input and the out were processed by the “2181” ALU, a detailed schematics were shown in Figure 2.

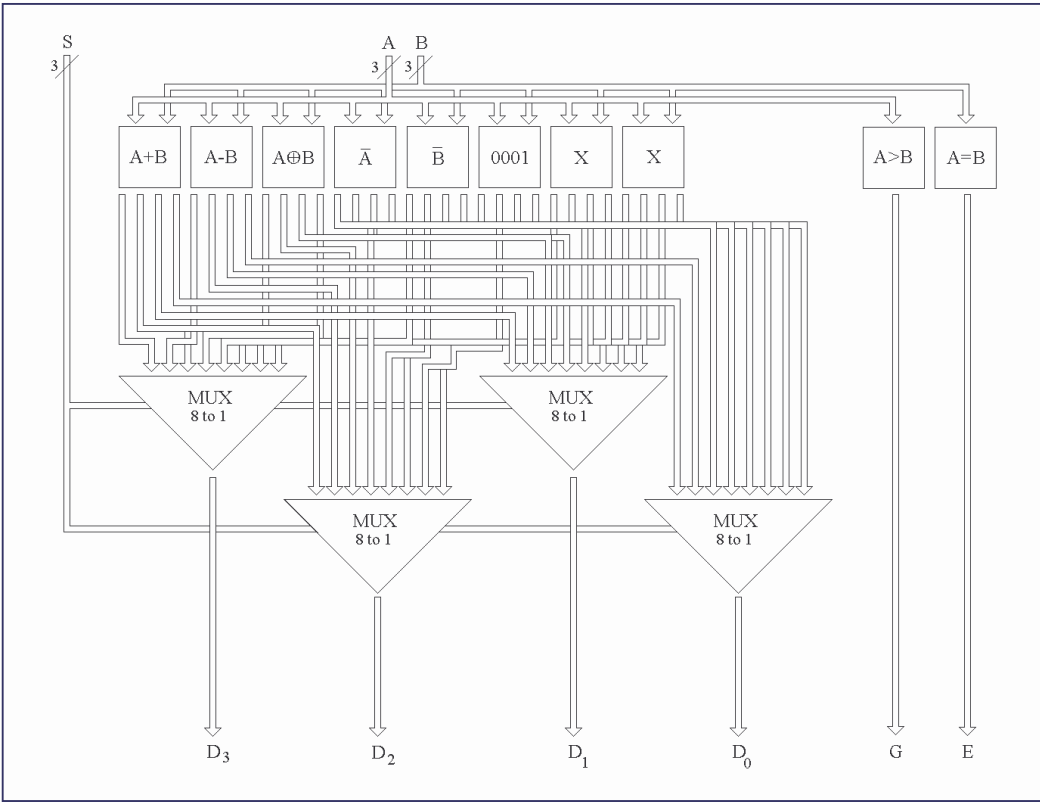

Figure 2: Detailed Schematics of the “2181” ALU

"2181" ALU CIRCUIT DIAGRAM

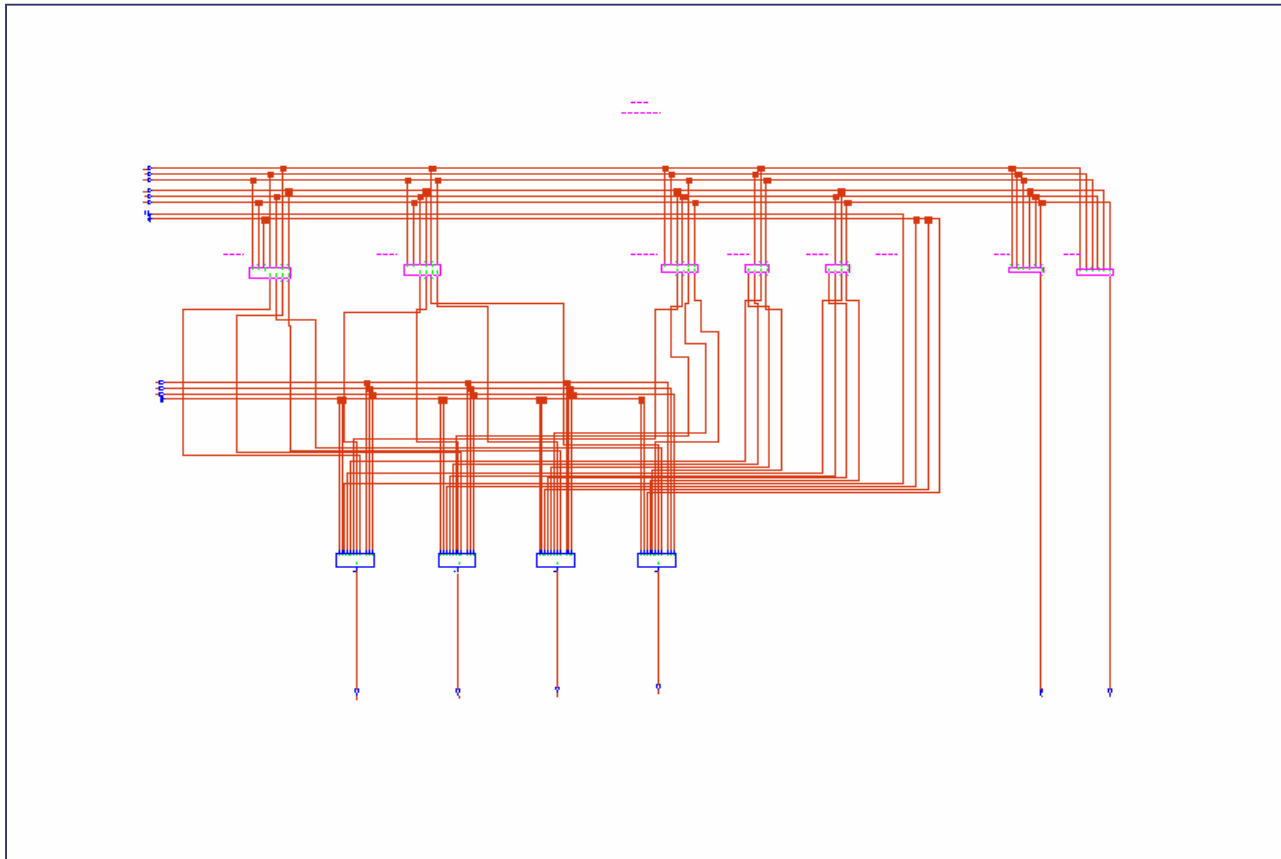

Figure 3: "2181" ALU Circuit Diagram

FUNCTION A + B: Block Diagram

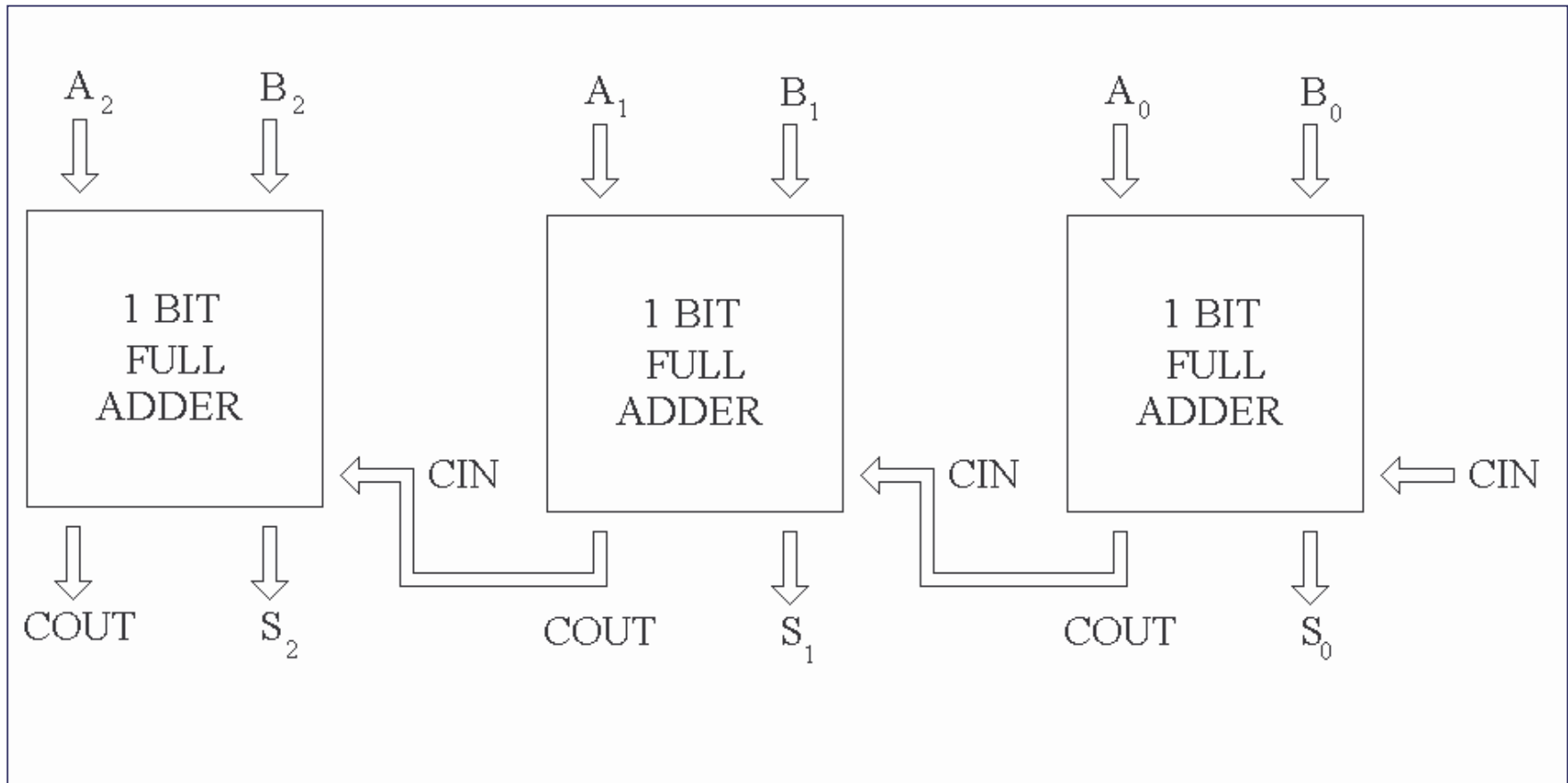

Figure 4: Function A+B Block Diagram

FUNCTION A + B: Modulus Schematics

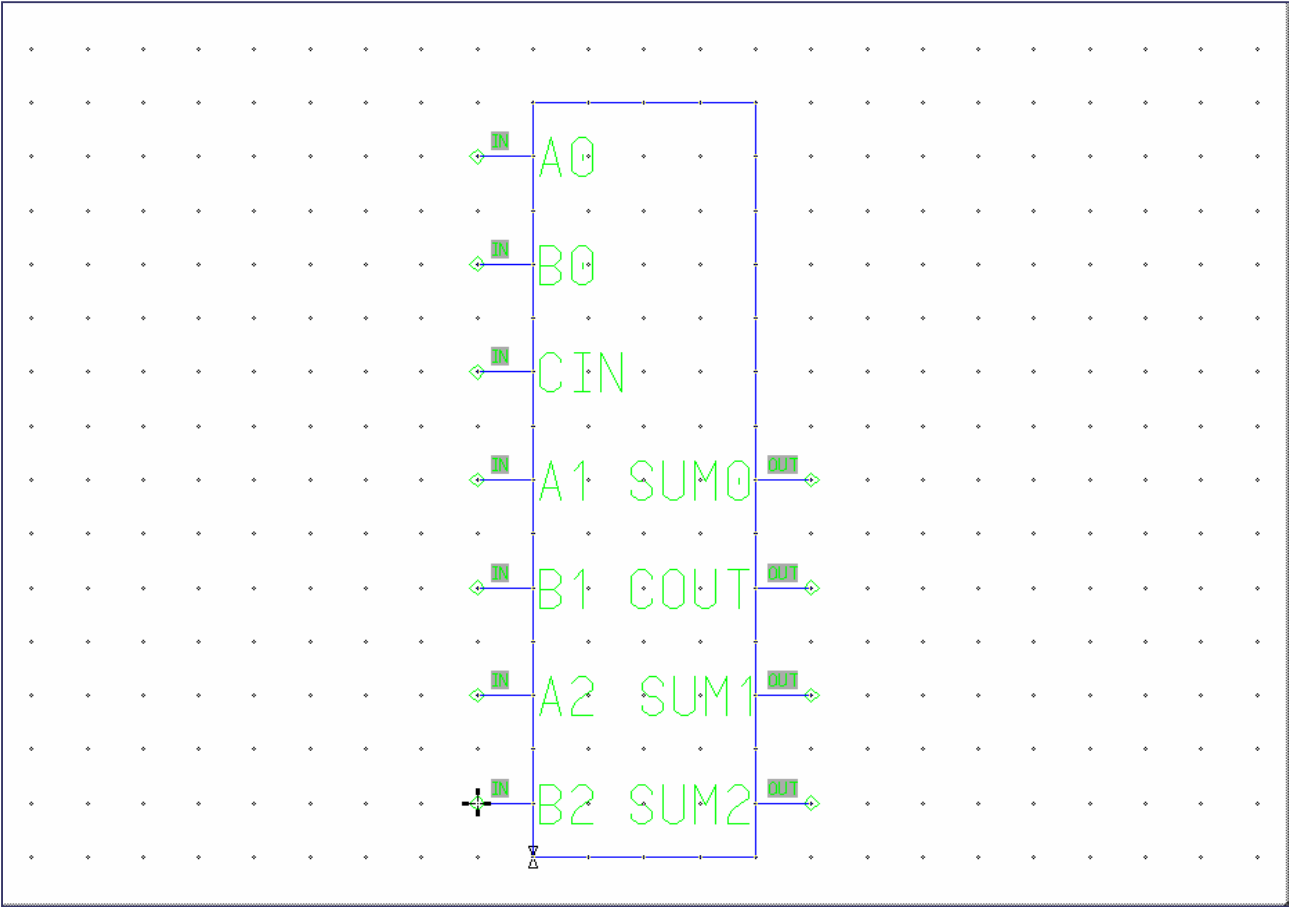

Figure 5: Function A+B Modulus Schematics

FUNCTION A+B: Modulus Circuit

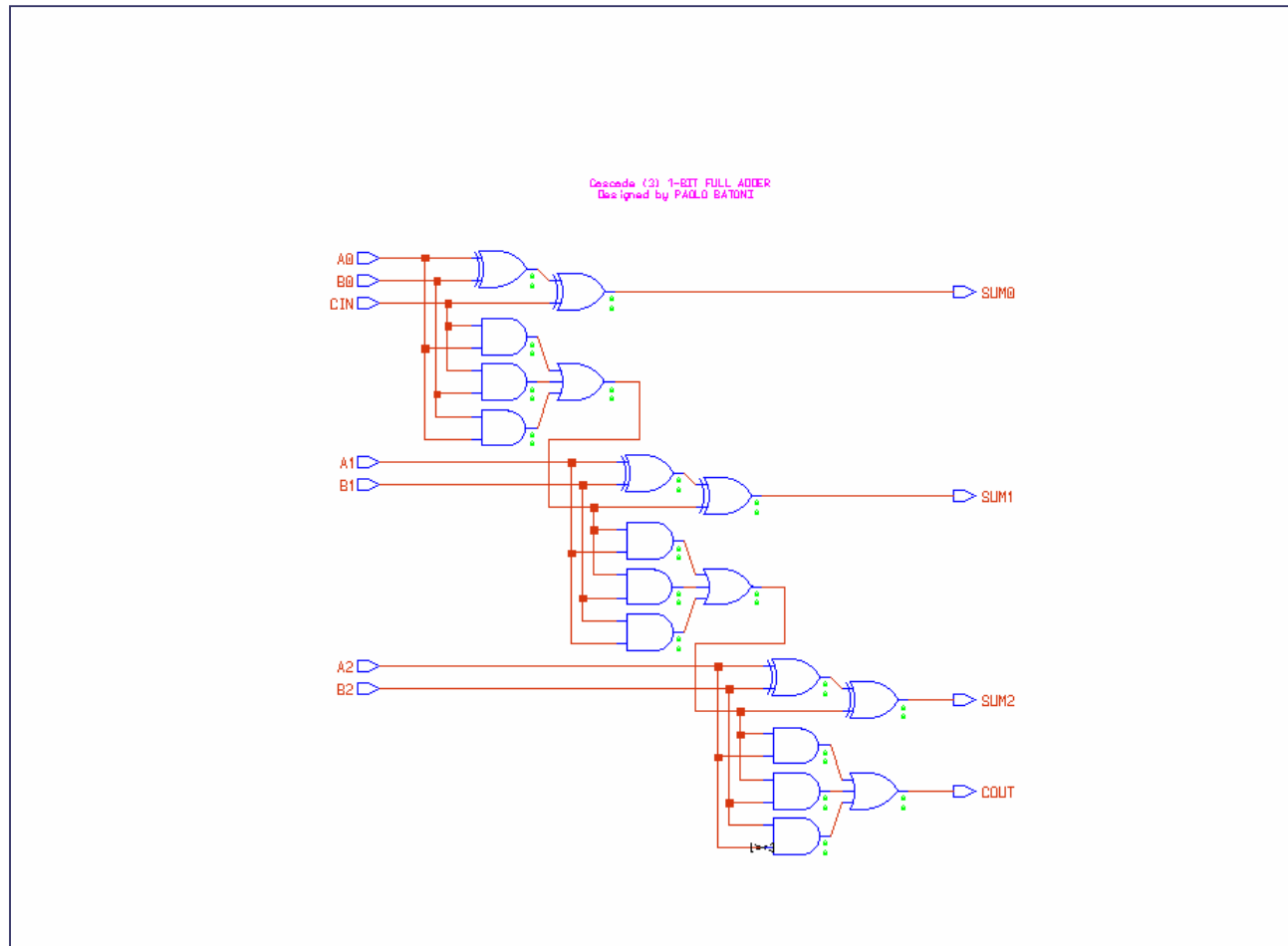

Figure 6: Function A+B Modulus Circuit

FUNCTION A - B: Block Diagram

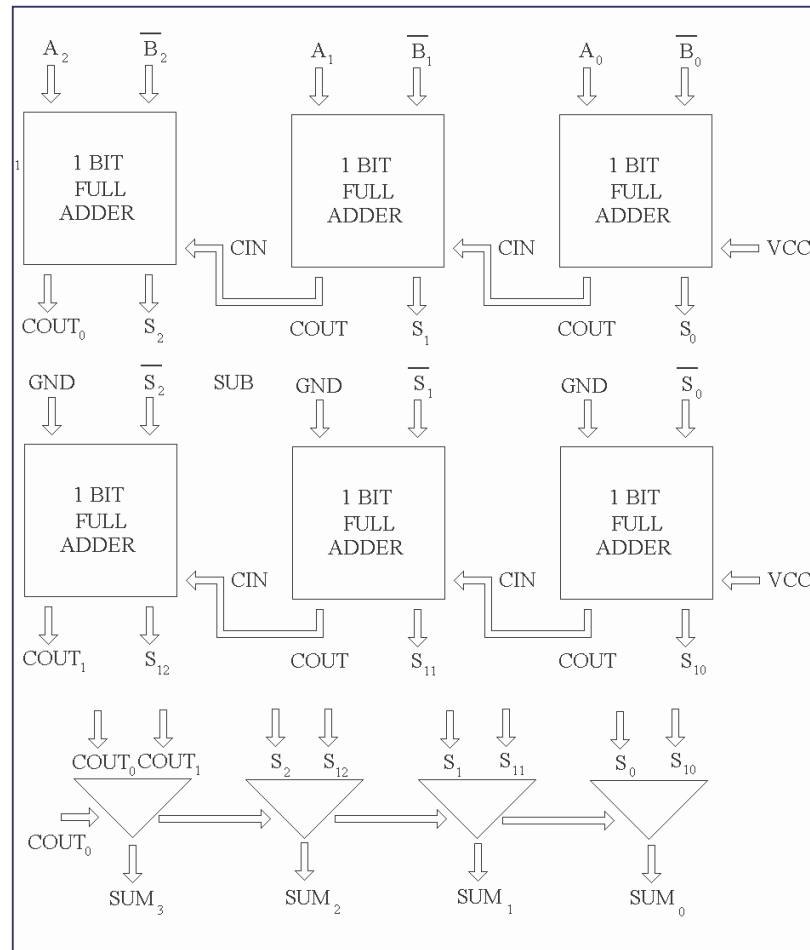

Figure 7: Function A-B Block Diagram

FUNCTION A - B: Modulus Schematics

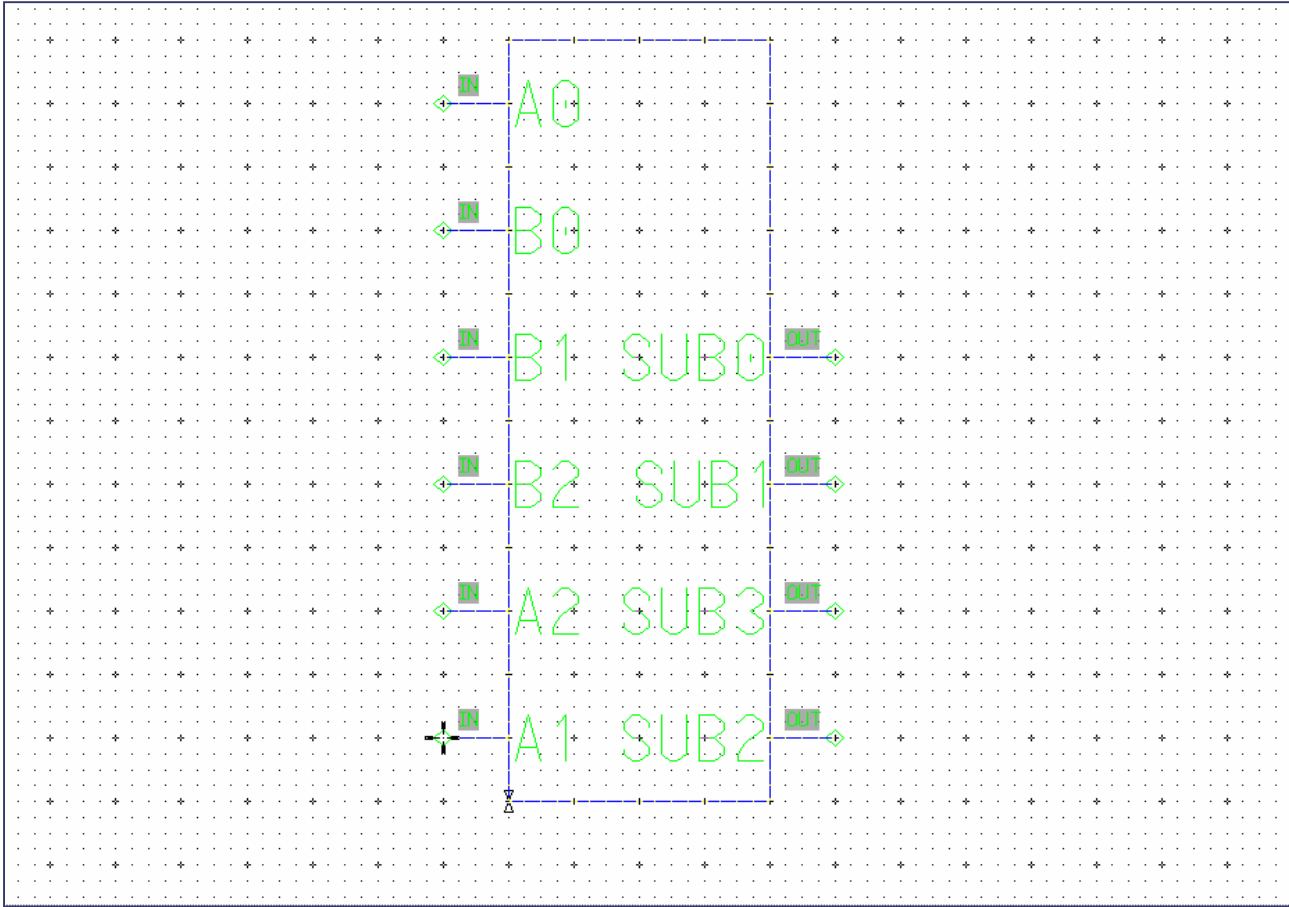

Figure 8: *Function A-B Modulus Schematics*

FUNCTION A - B: Modulus Circuit

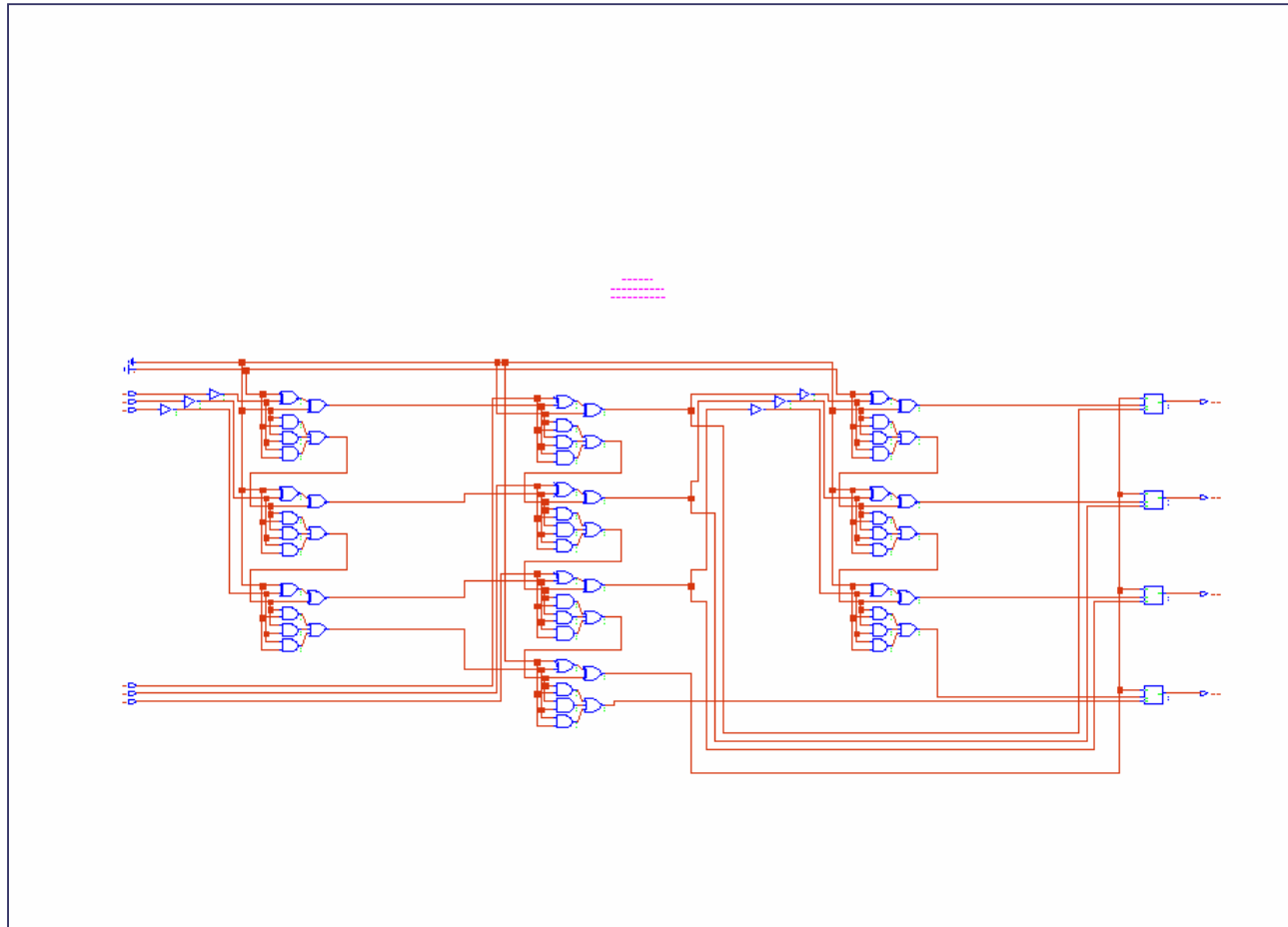

Figure 9: Function A-B Modulus Circuit

FUNCTION $A \oplus B$: Block Diagram

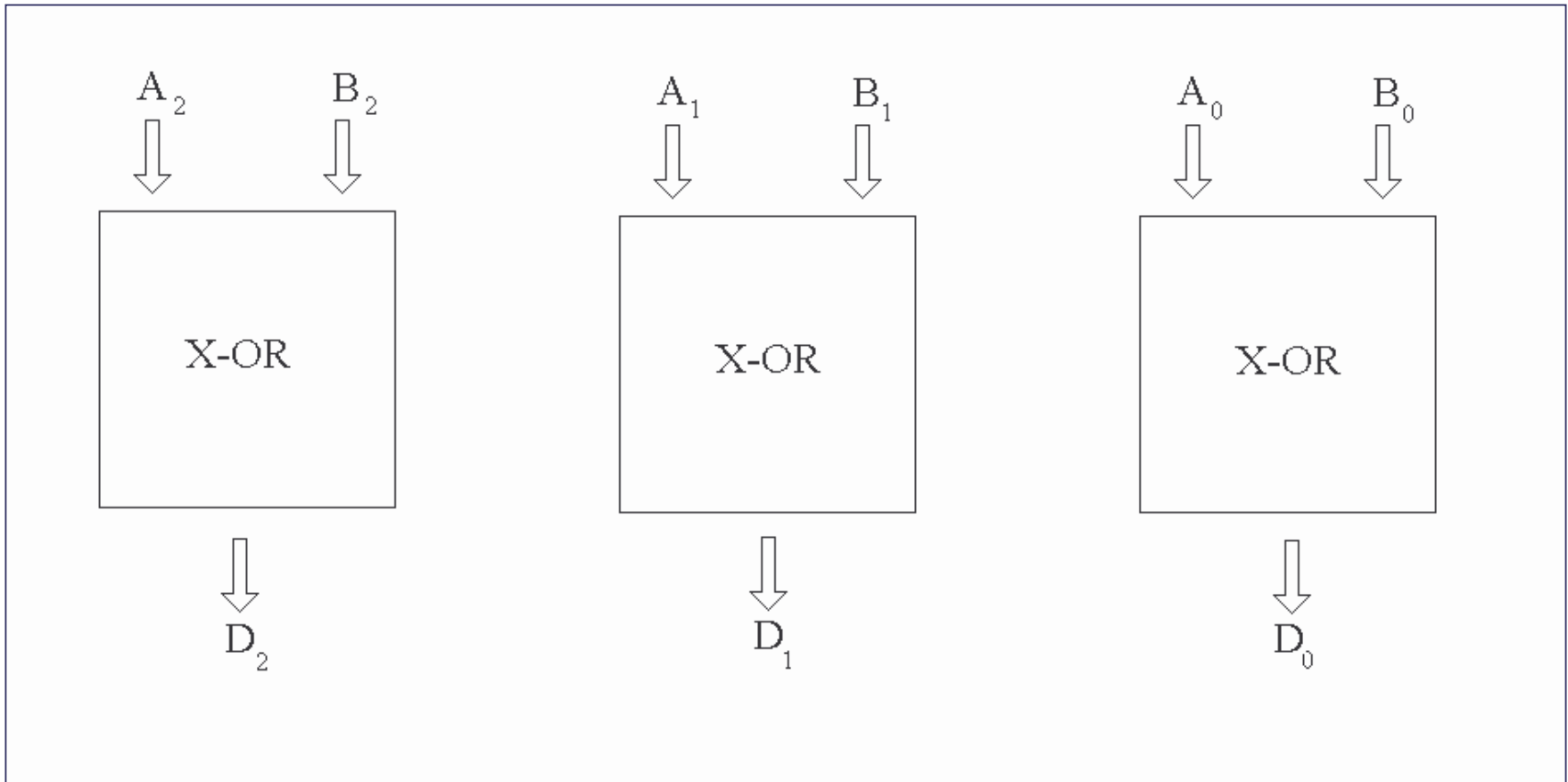

Figure 10: *Function $A \oplus B$ Block Diagram*

FUNCTION $A \oplus B$: Modulus Schematics

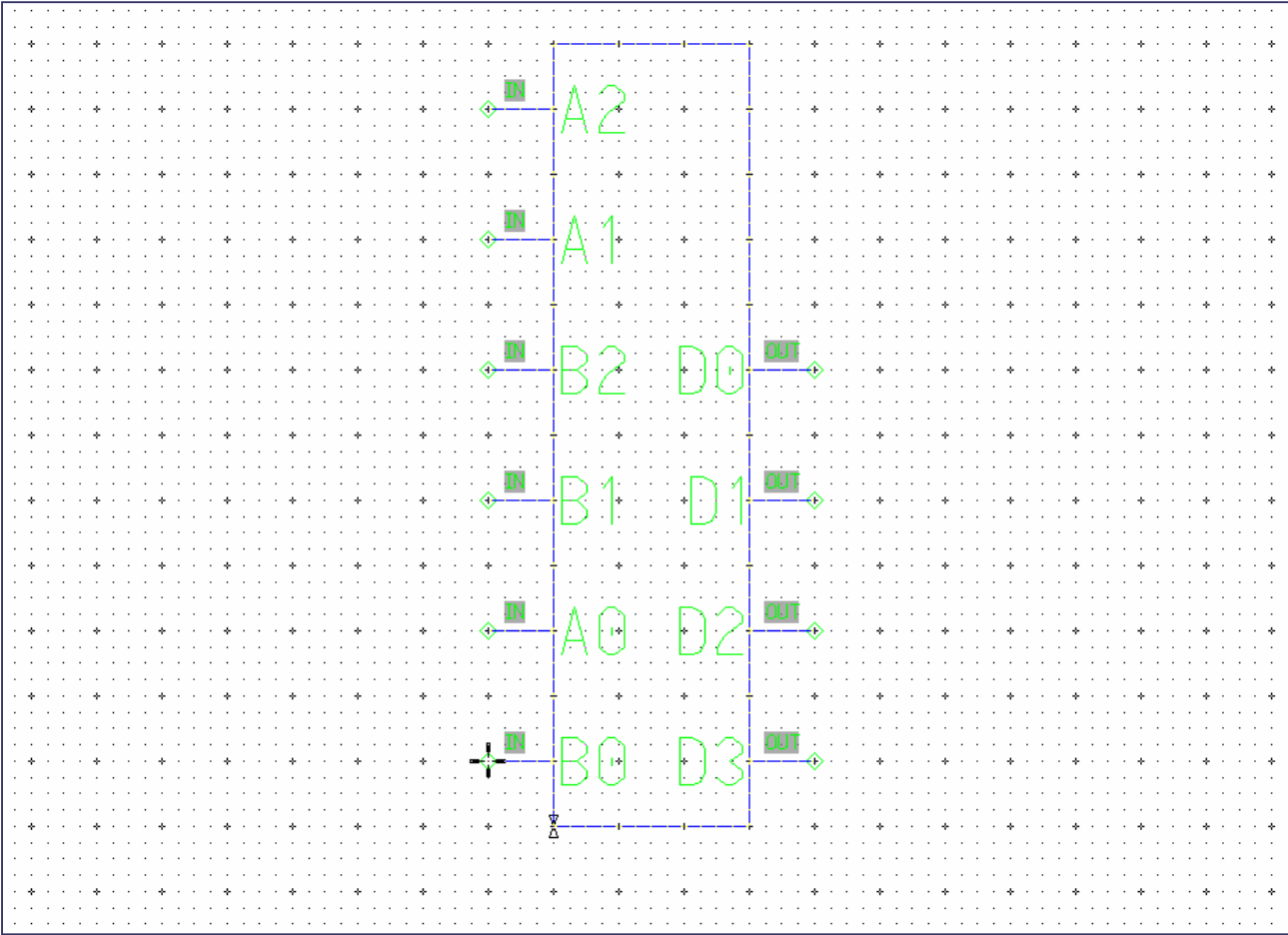

Figure 11: *Function $A \oplus B$ Modulus Schematics*

FUNCTION $A \oplus B$: Modulus Circuit

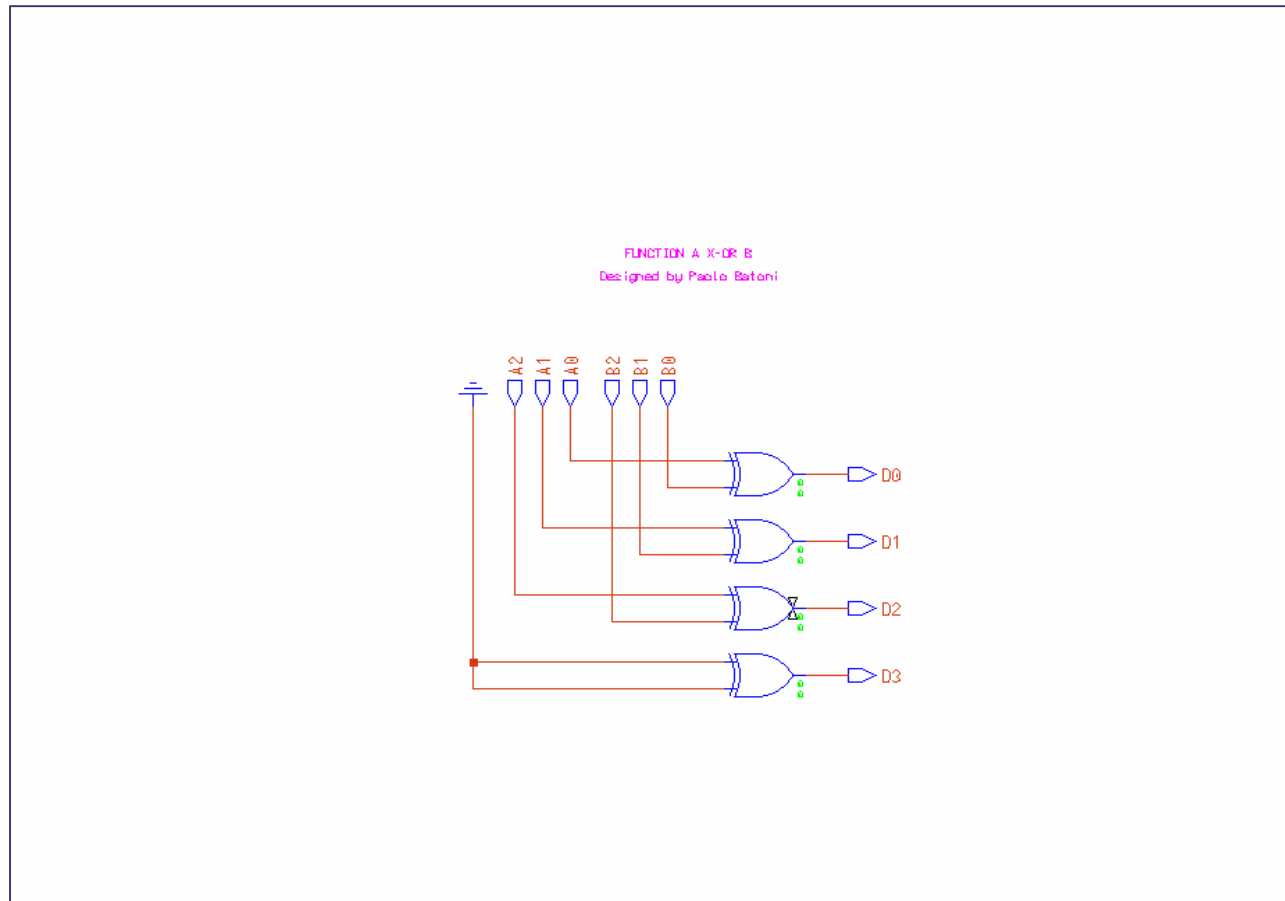

Figure 12: Function $A \oplus B$ Modulus Circuit

FUNCTION A': Block Diagram

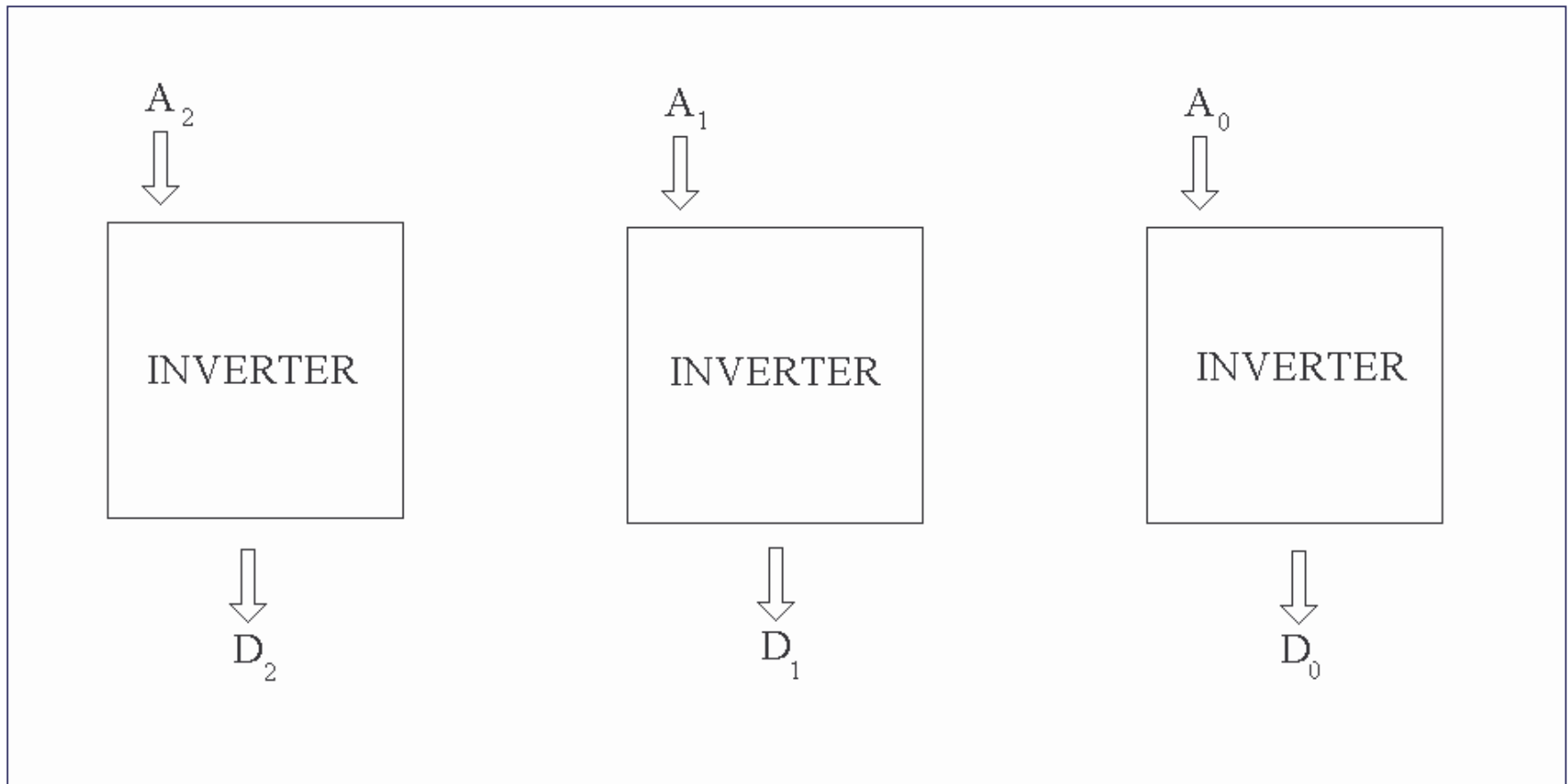

Figure 13: *Function A' Block Diagram*

FUNCTION A': Modulus Schematics

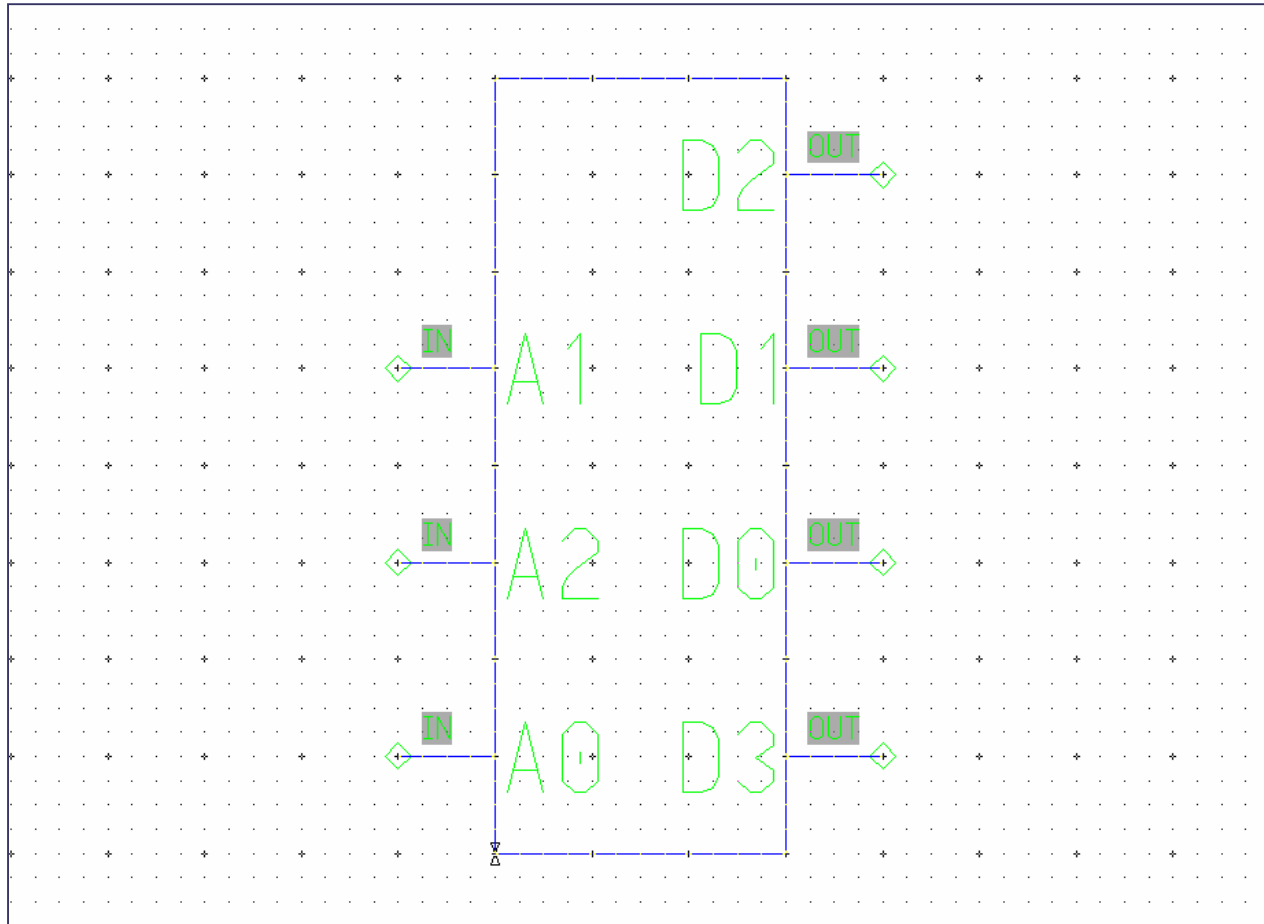

Figure 14: Function A' Modulus Schematics

FUNCTION A': Modulus Circuit

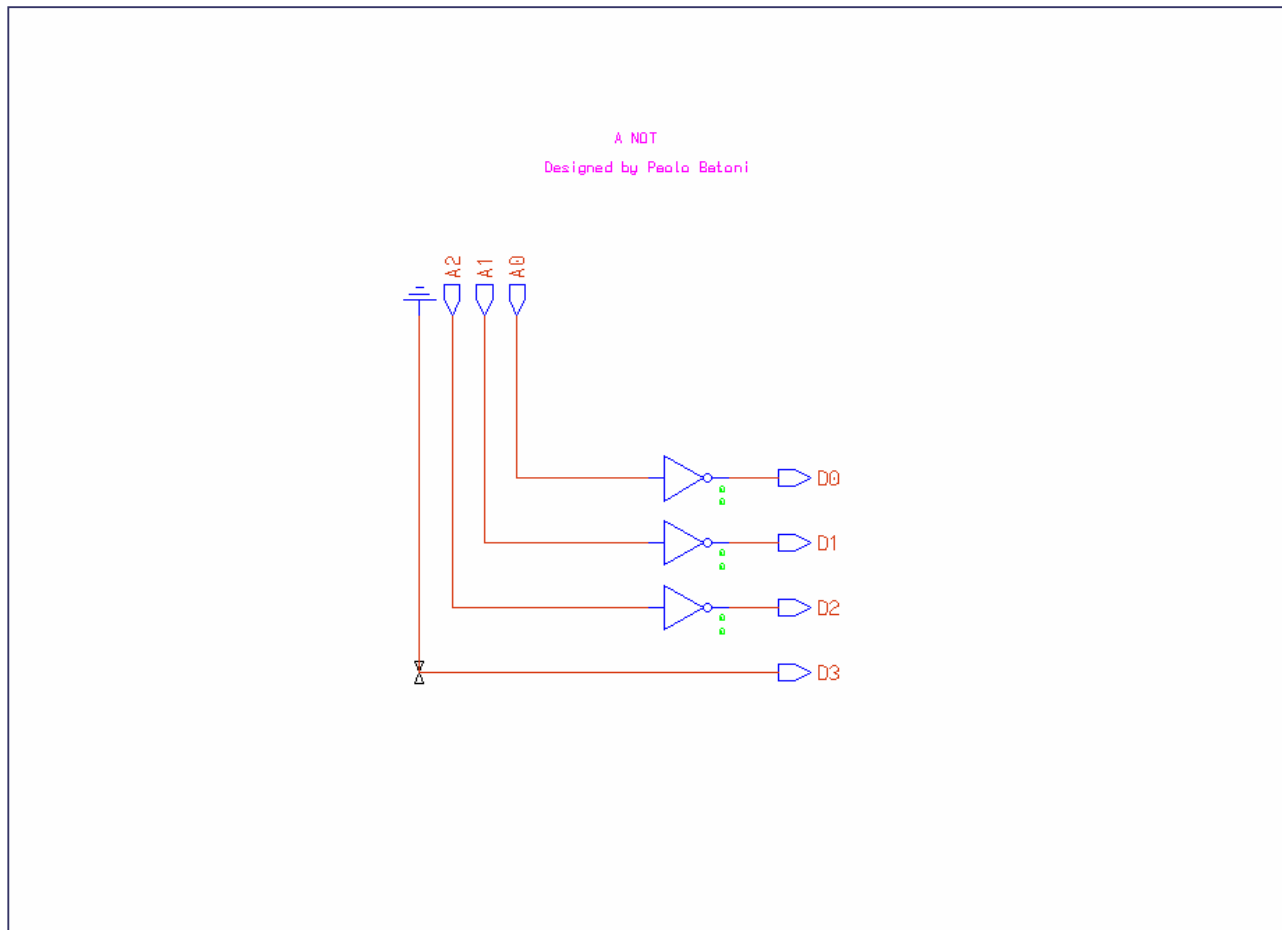

Figure 15: Function A' Modulus Circuit

FUNCTION B': Block Diagram

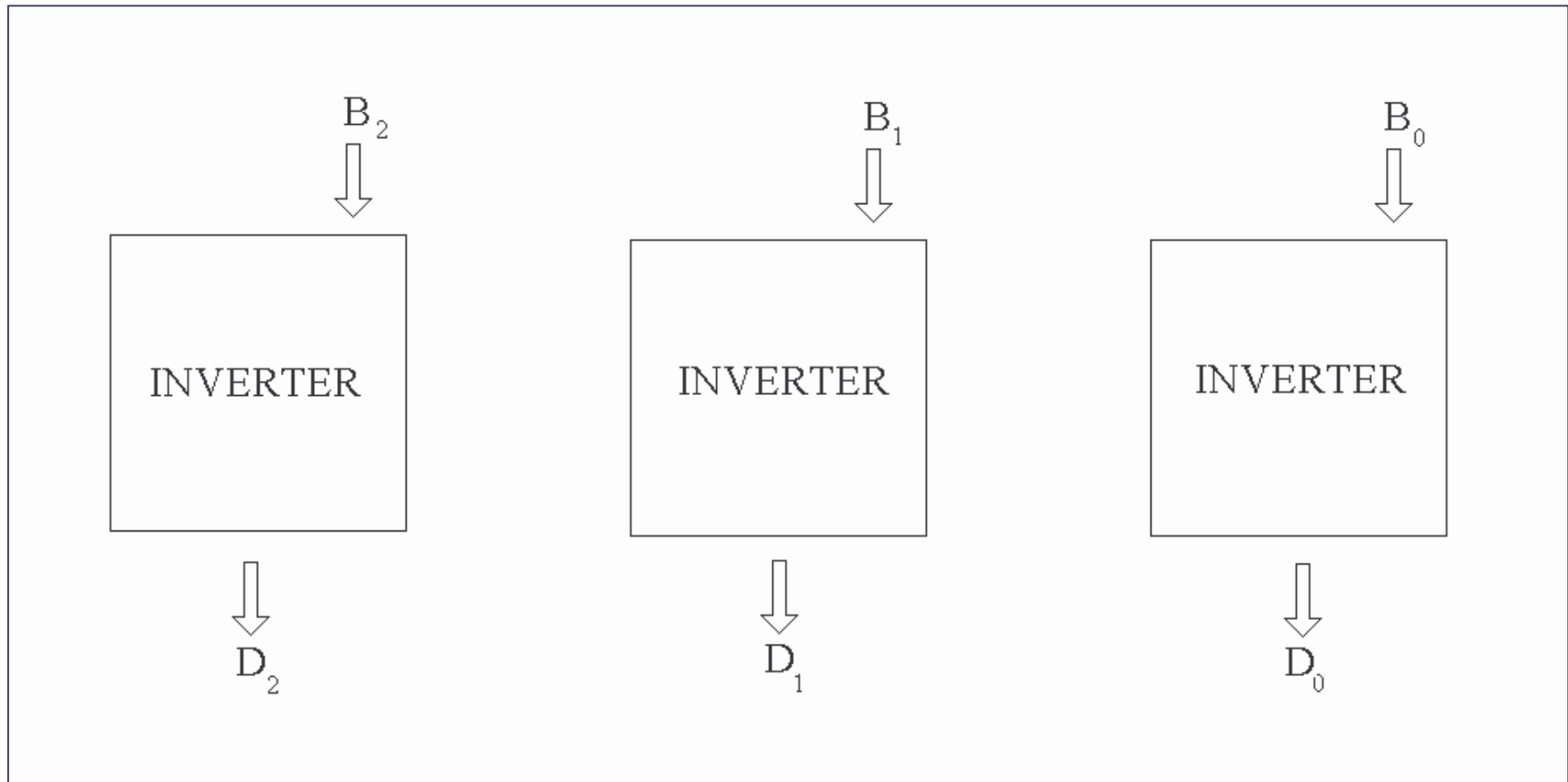

Figure 16: *Function B' Block Diagram*

FUNCTION B': Modulus Schematics

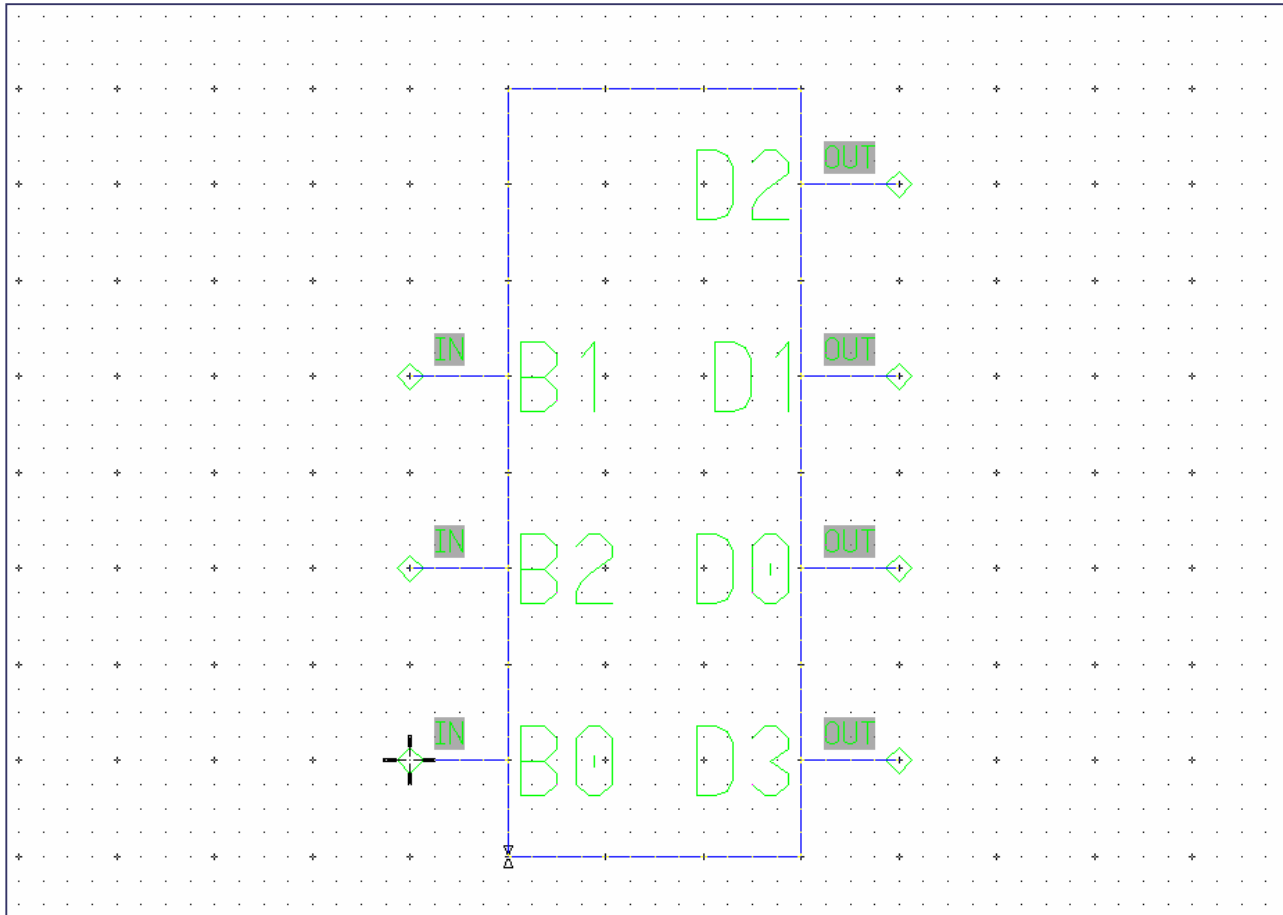

Figure 17: Function B' Modulus Schematics

FUNCTION B': Modulus Circuit

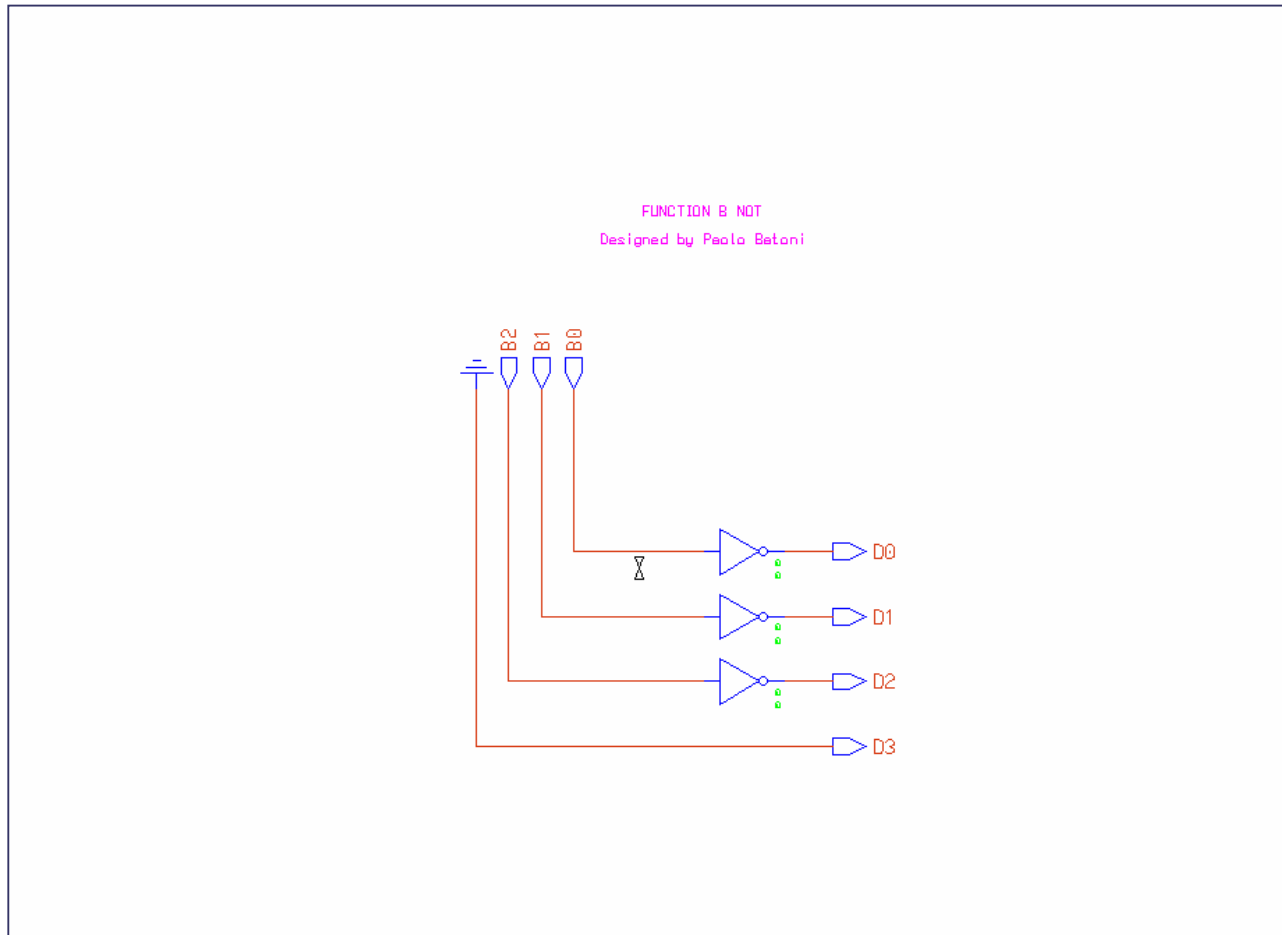

Figure 18: Function B' Modulus Circuit

FUNCTION 0001: Modulus Schematics

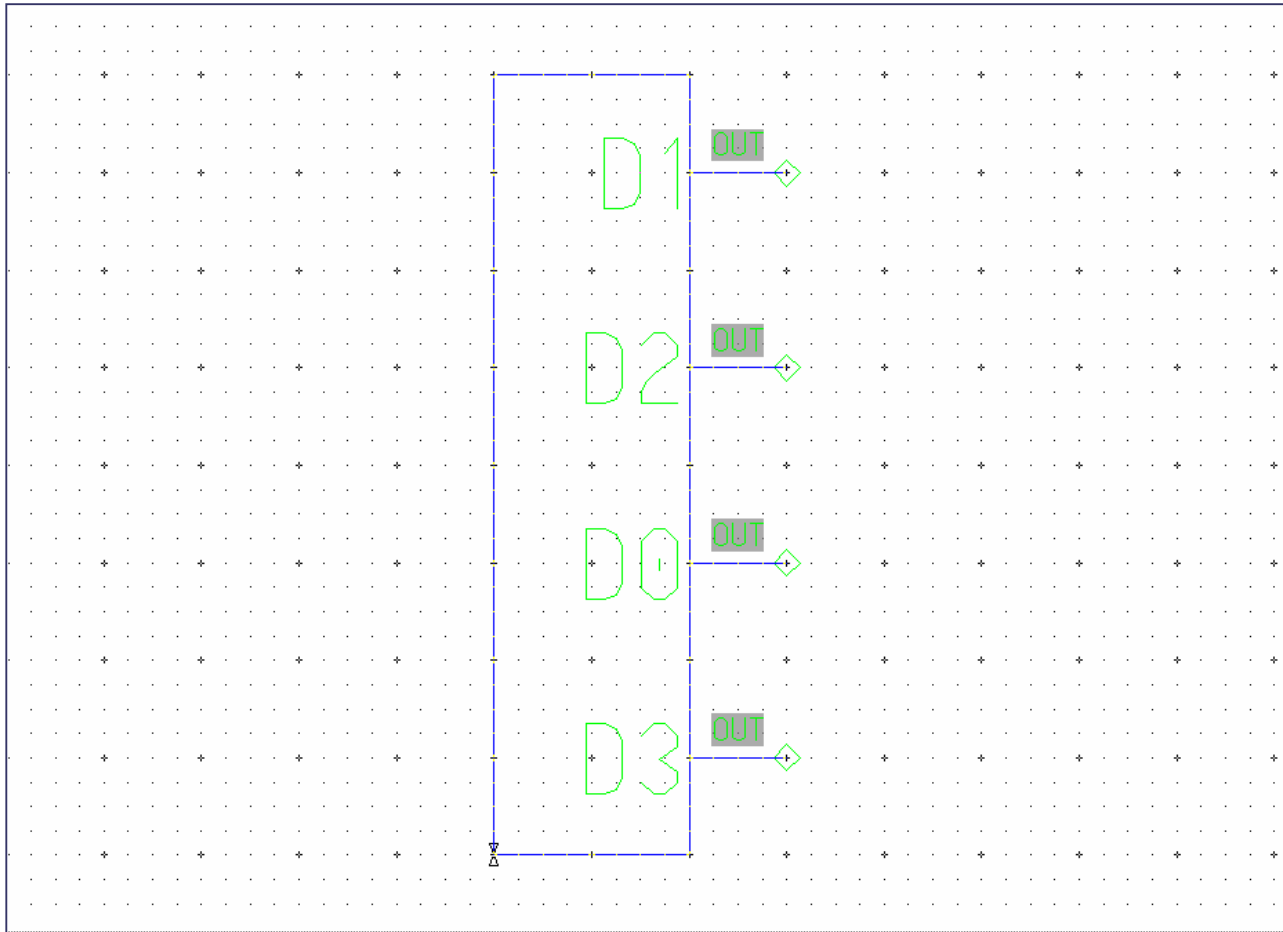

Figure 19: Function 0001 Modulus Schematics

FUNCTION 0001: Modulus Circuit

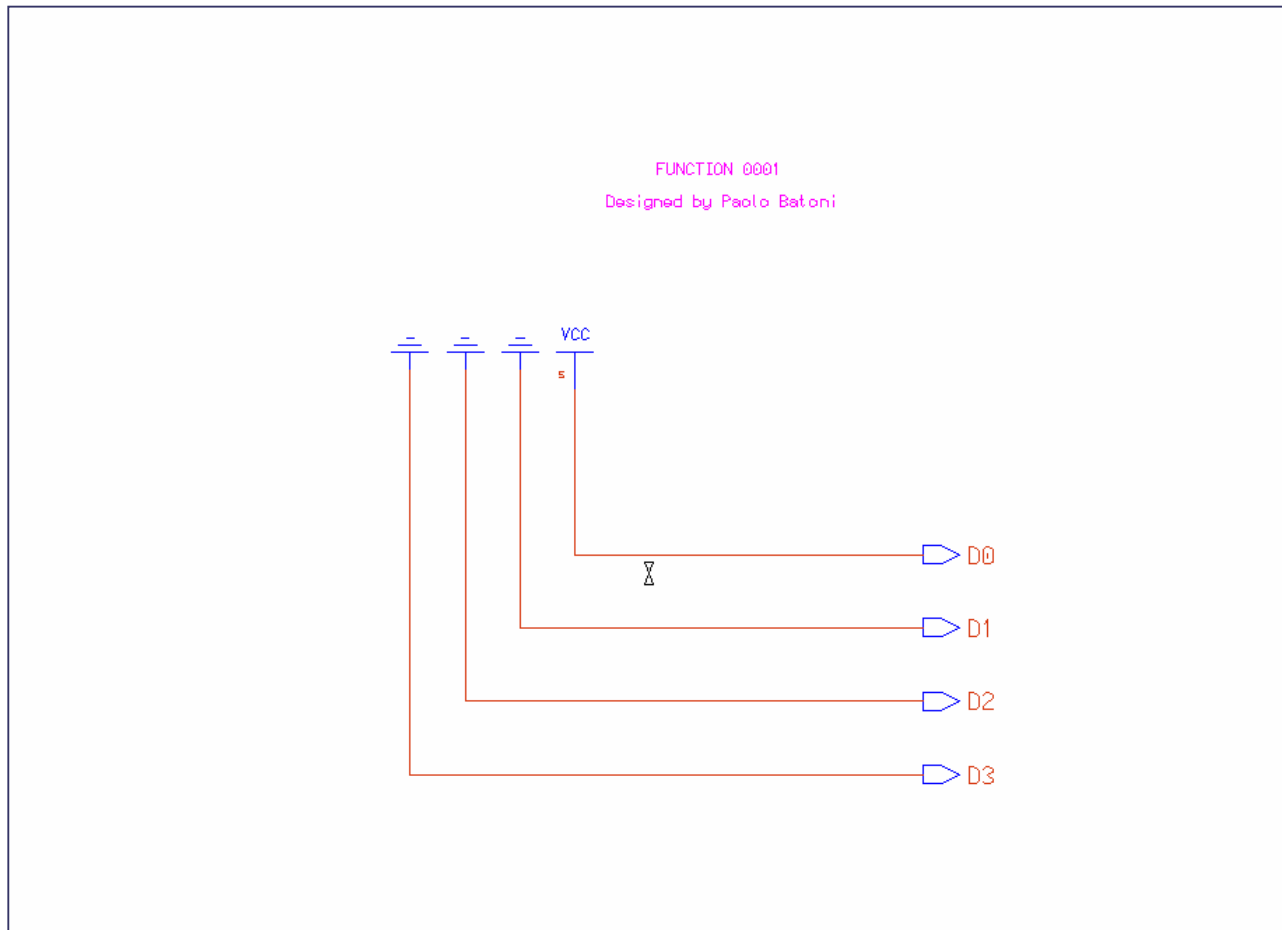

Figure 20: *Function 0001 Modulus Circuit*

FUNCTION 2'S of A: Block Diagram

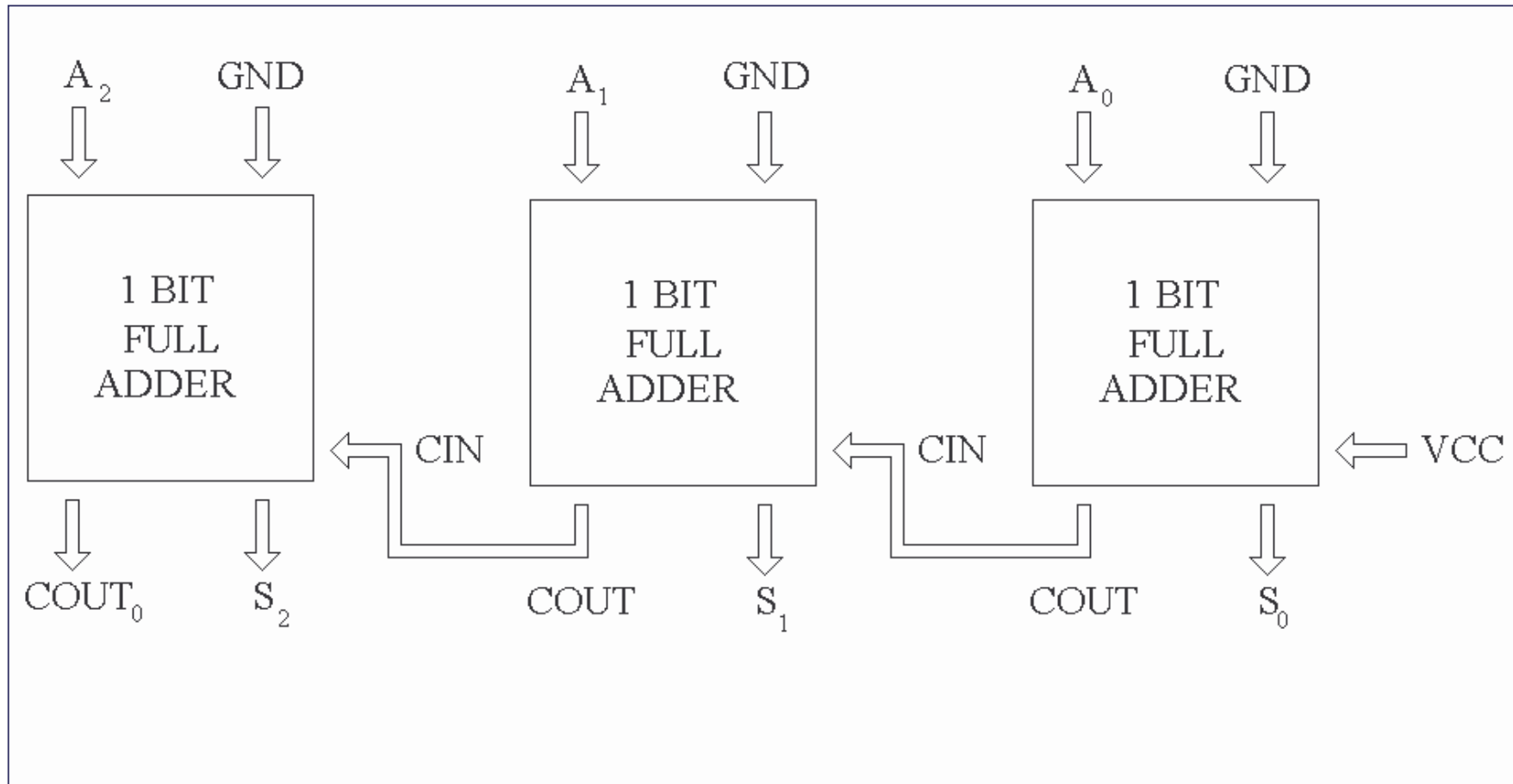

Figure 21: 2'S Complement of A Block Diagram

FUNCTION 2'S of A: Modulus Schematics

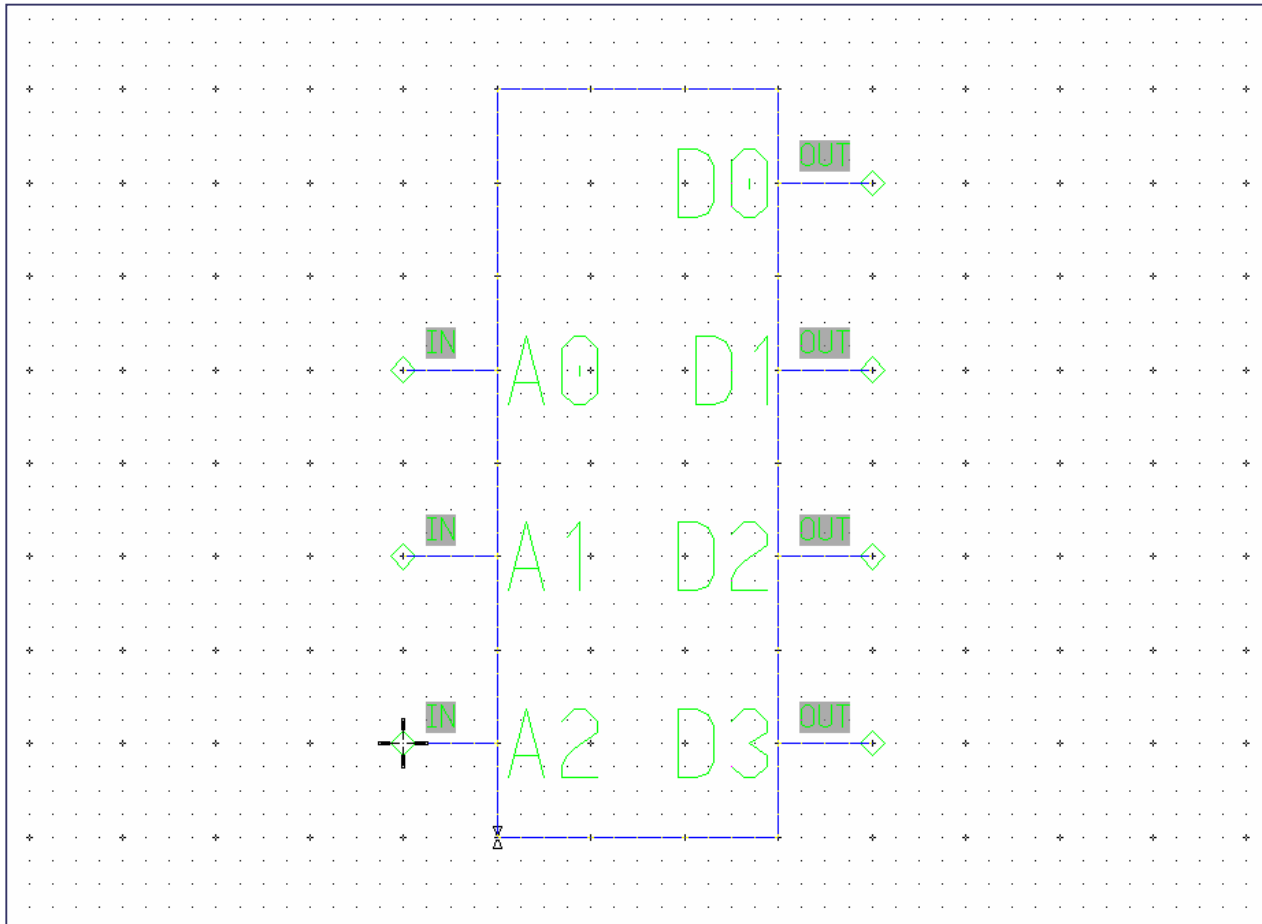

Figure 22: Function 2'S of A Modulus Schematics

FUNCTION 2'S of A: Modulus Circuit

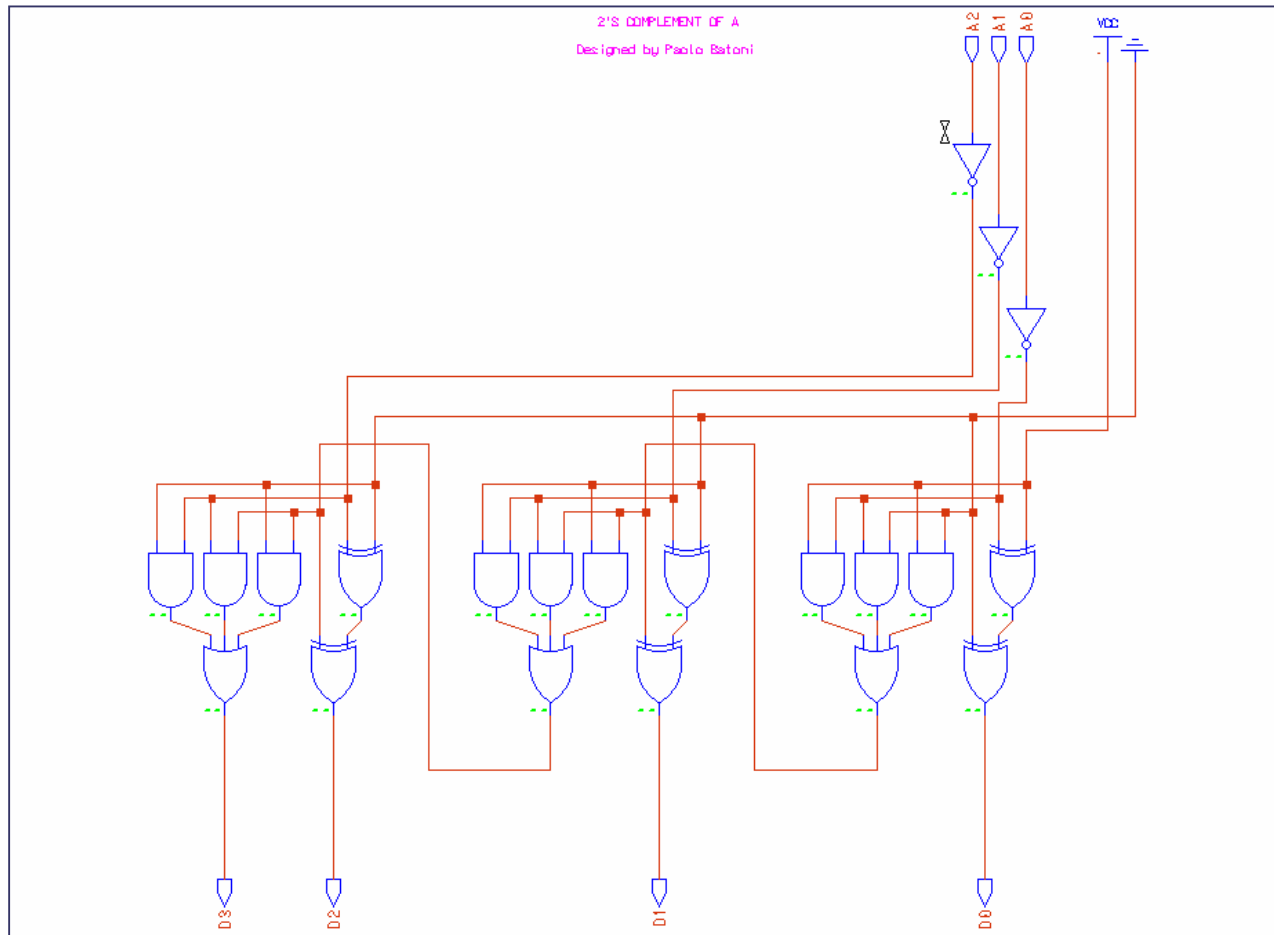

Figure 23: 2'S of A Modulus Circuit

FUNCTION A NAND B: Block Diagram

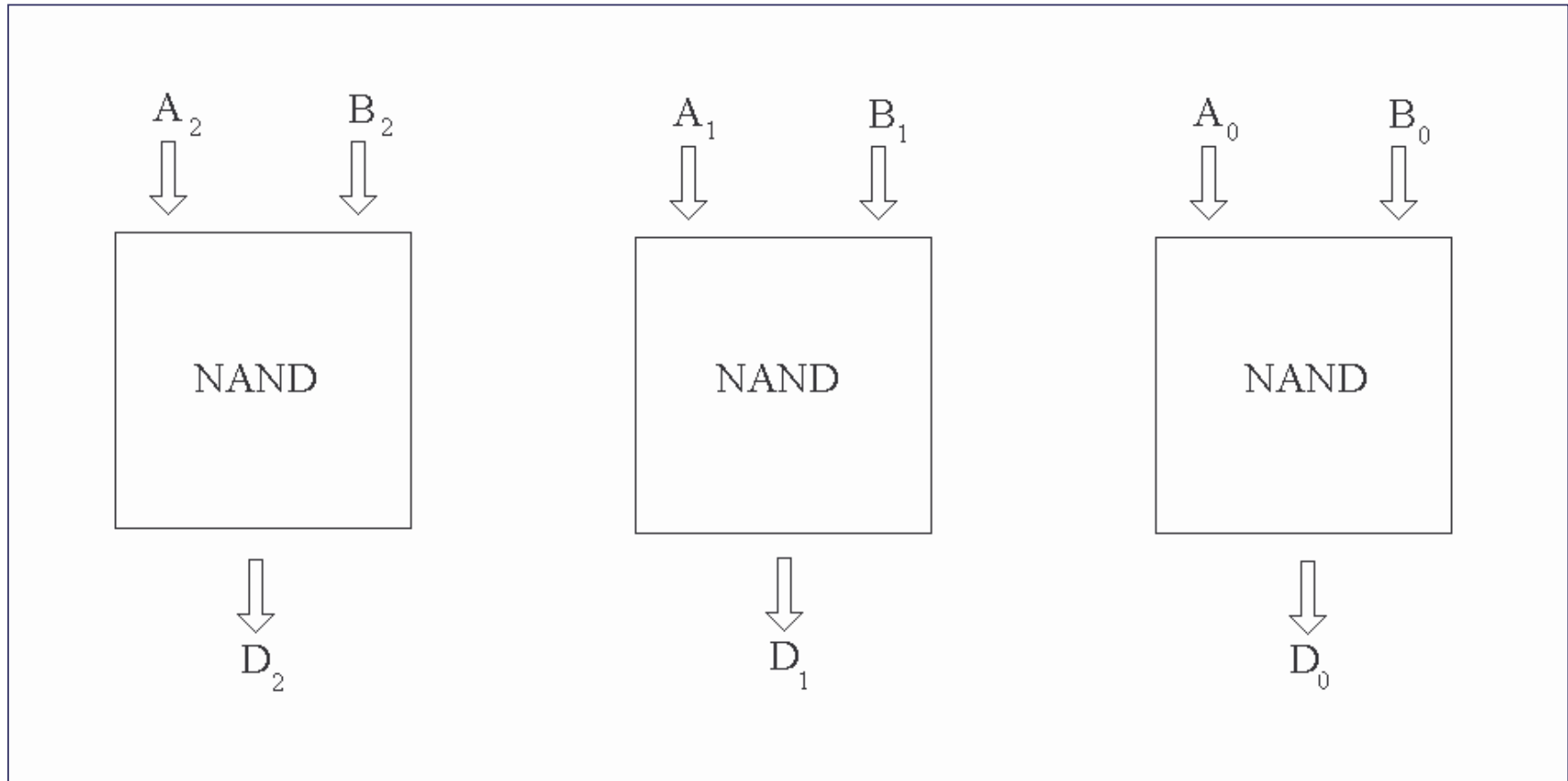

Figure 24: Function A NAND B Block Diagram

FUNCTION A NAND B: Modulus Schematics

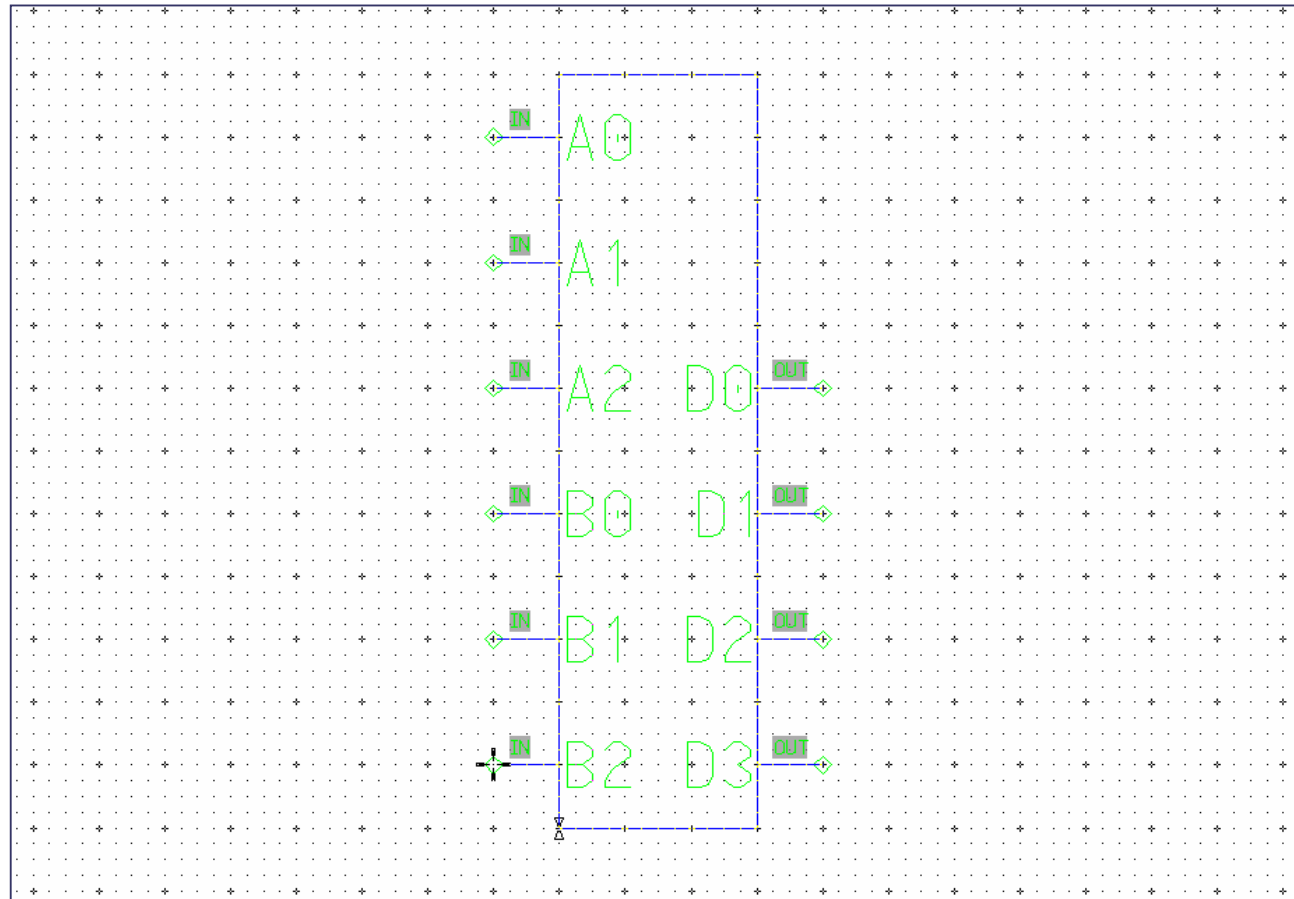

Figure 25: Function A NAND B Modulus Schematics

FUNCTION A NAND B: Modulus Circuit

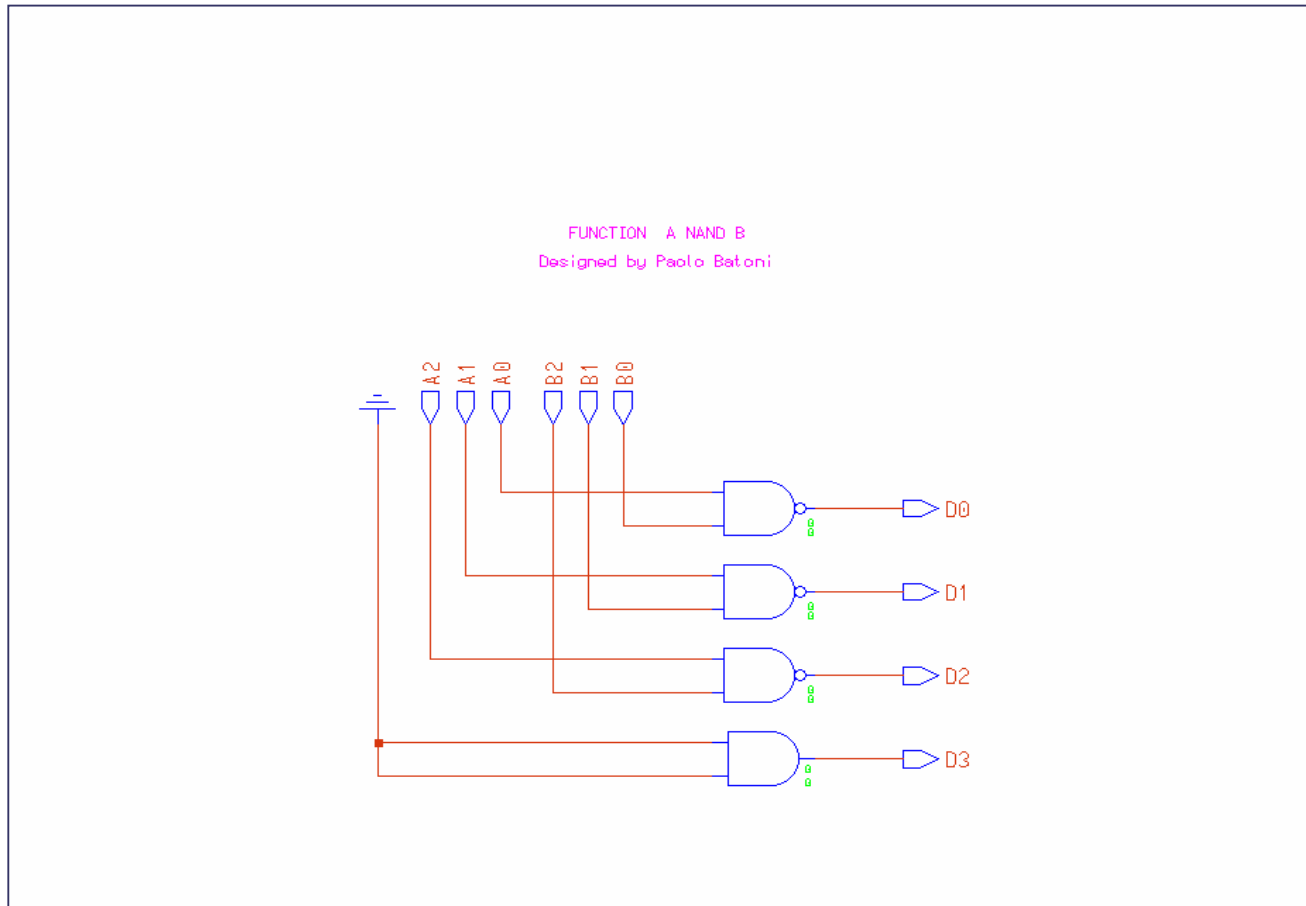

Figure 26: *Function A NAND B Modulus Circuit*

FUNCTION G: Modulus Schematics

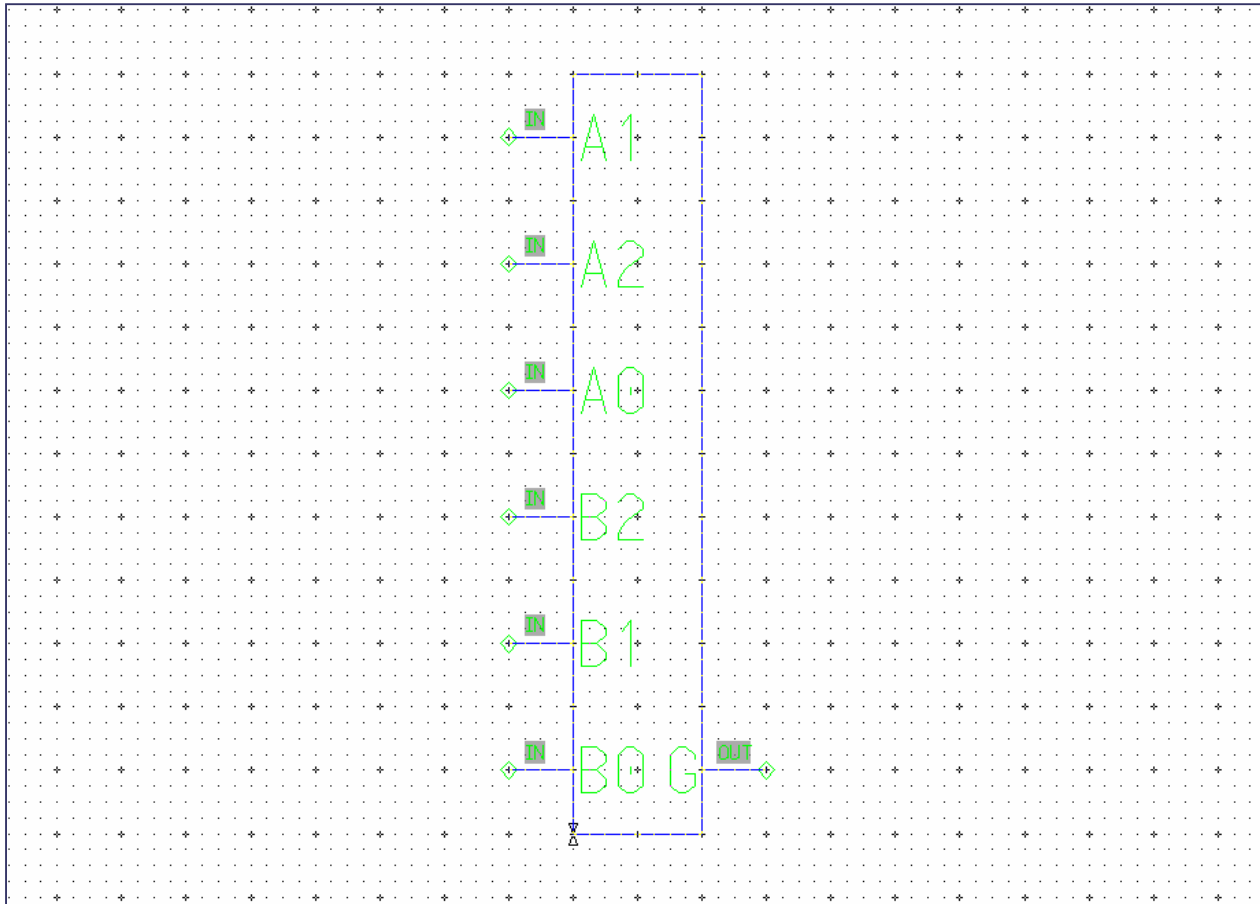

Figure 27: Function G Modulus Schematics

FUNCTION G: Modulus Circuit

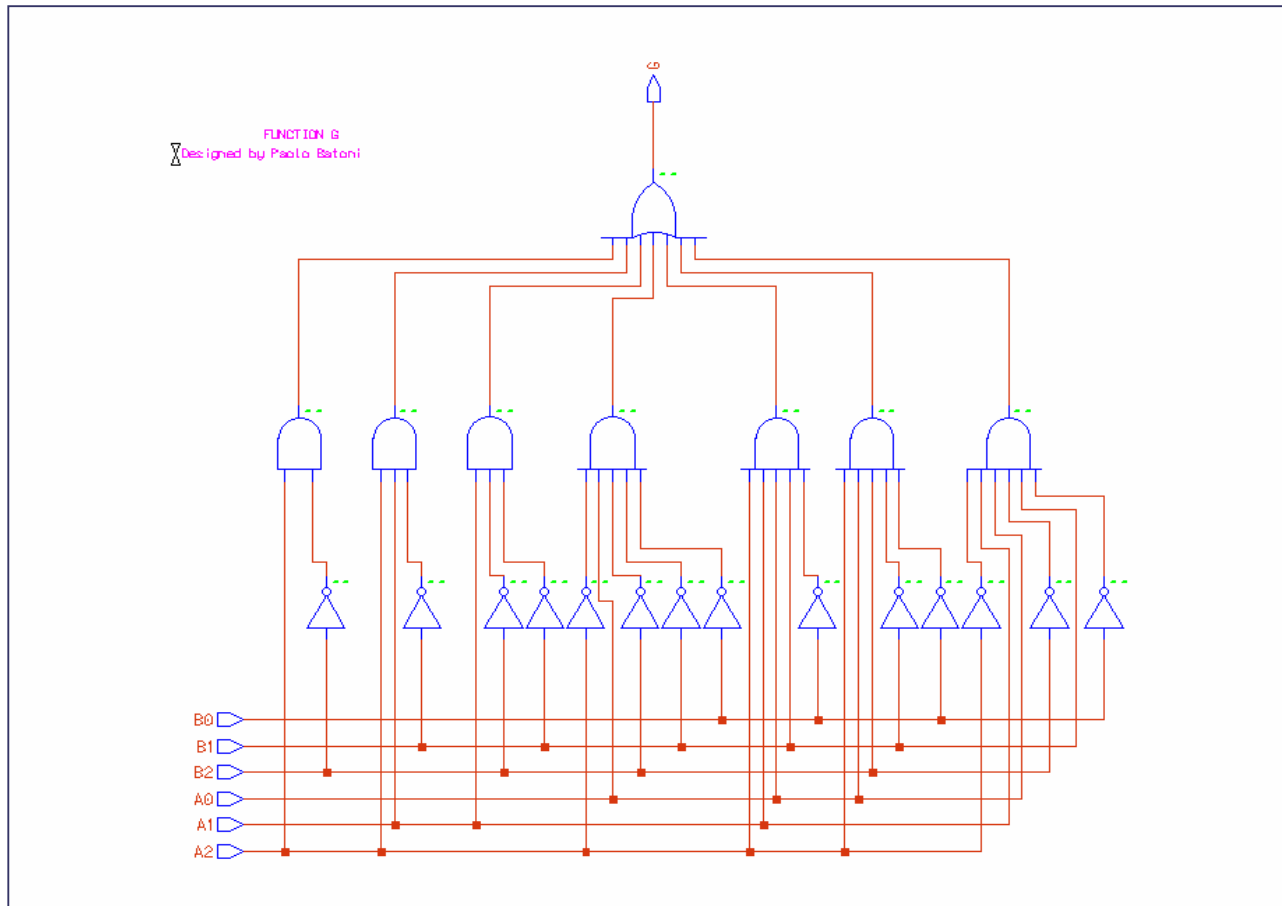

Figure 28: Function G Modulus Circuit

FUNCTION E: Modulus Schematics

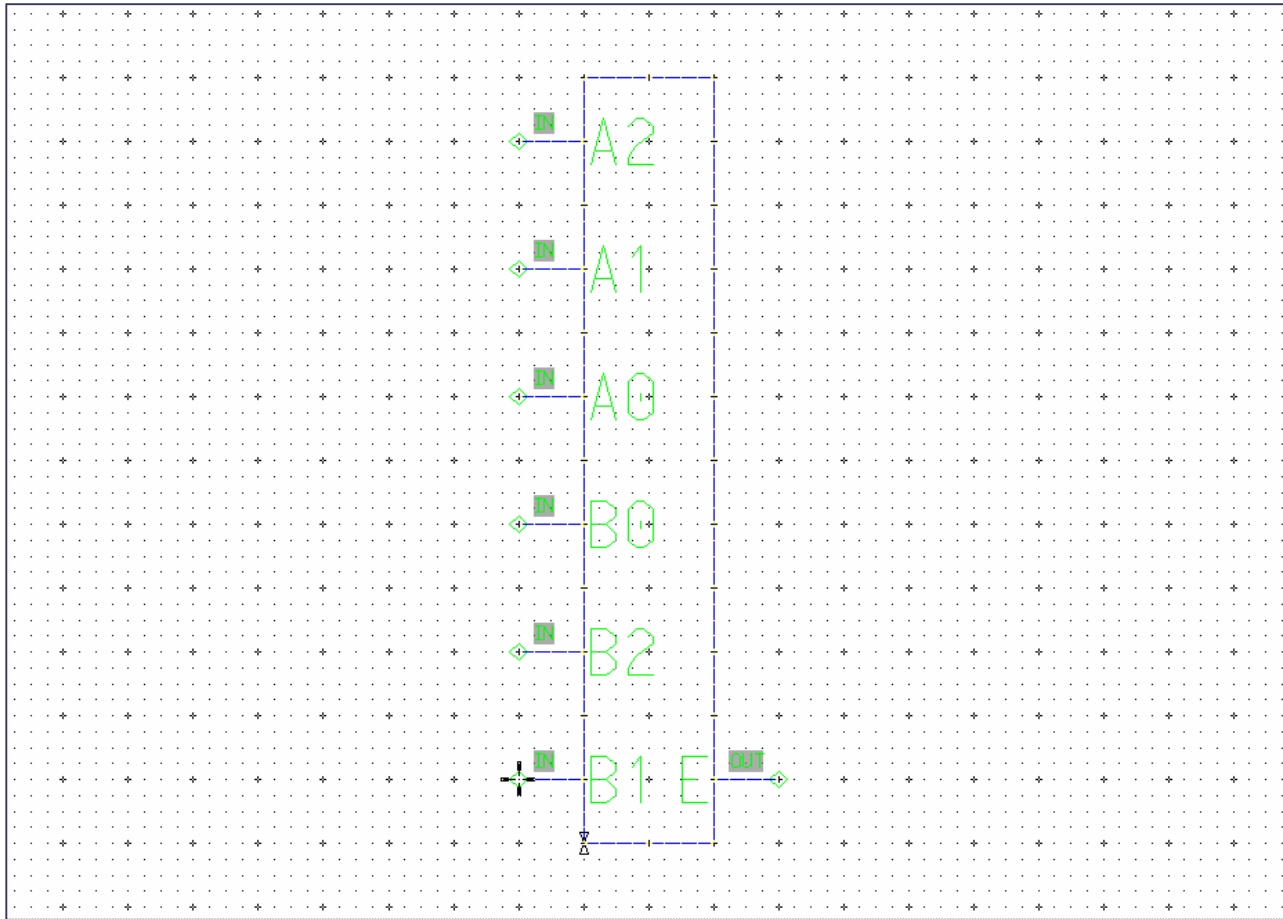

Figure 29: Function E Modulus Schematics

FUNCTION E: Modulus Circuit

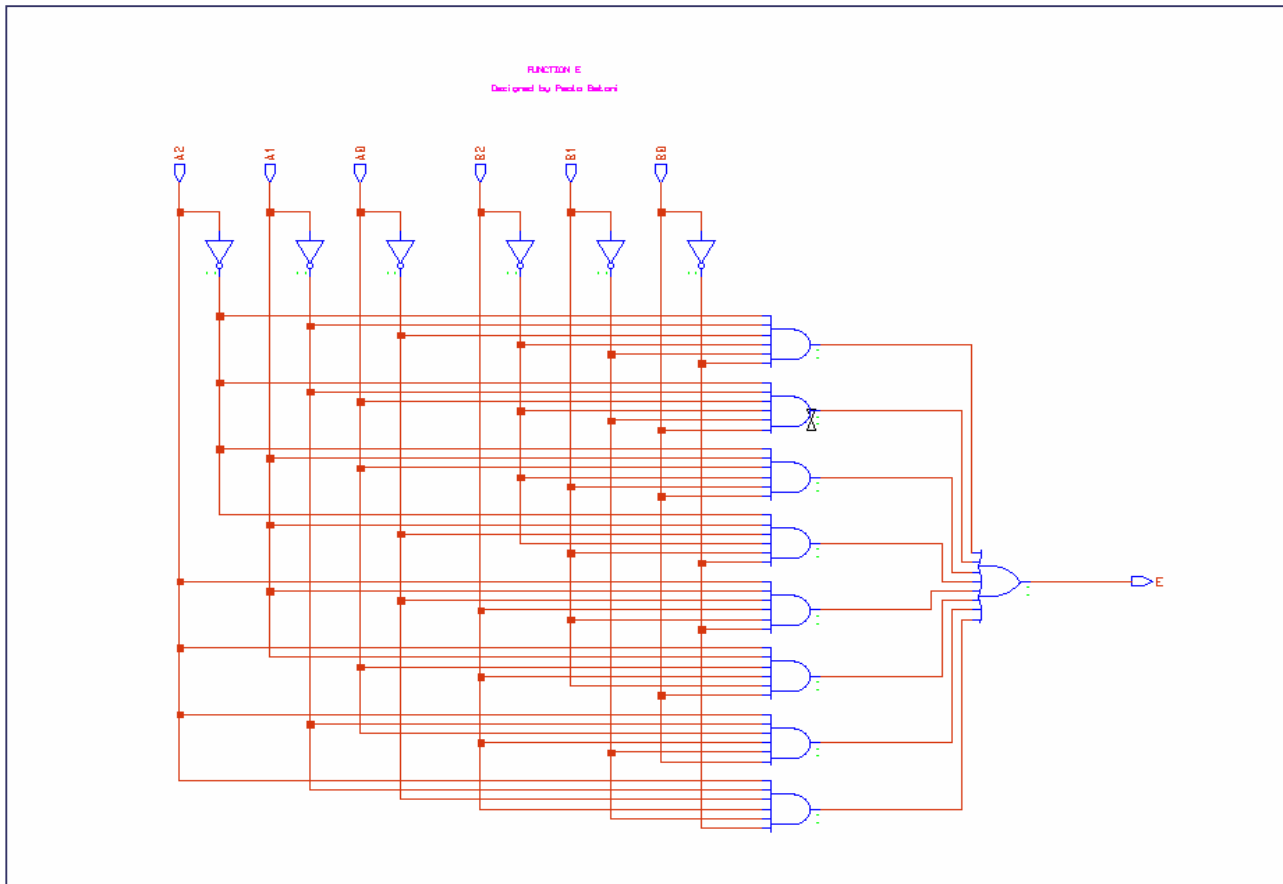

Figure 30: Function E Modulus Circuit

8-TO-1 MULTIPLEXOR: Modulus Schematics

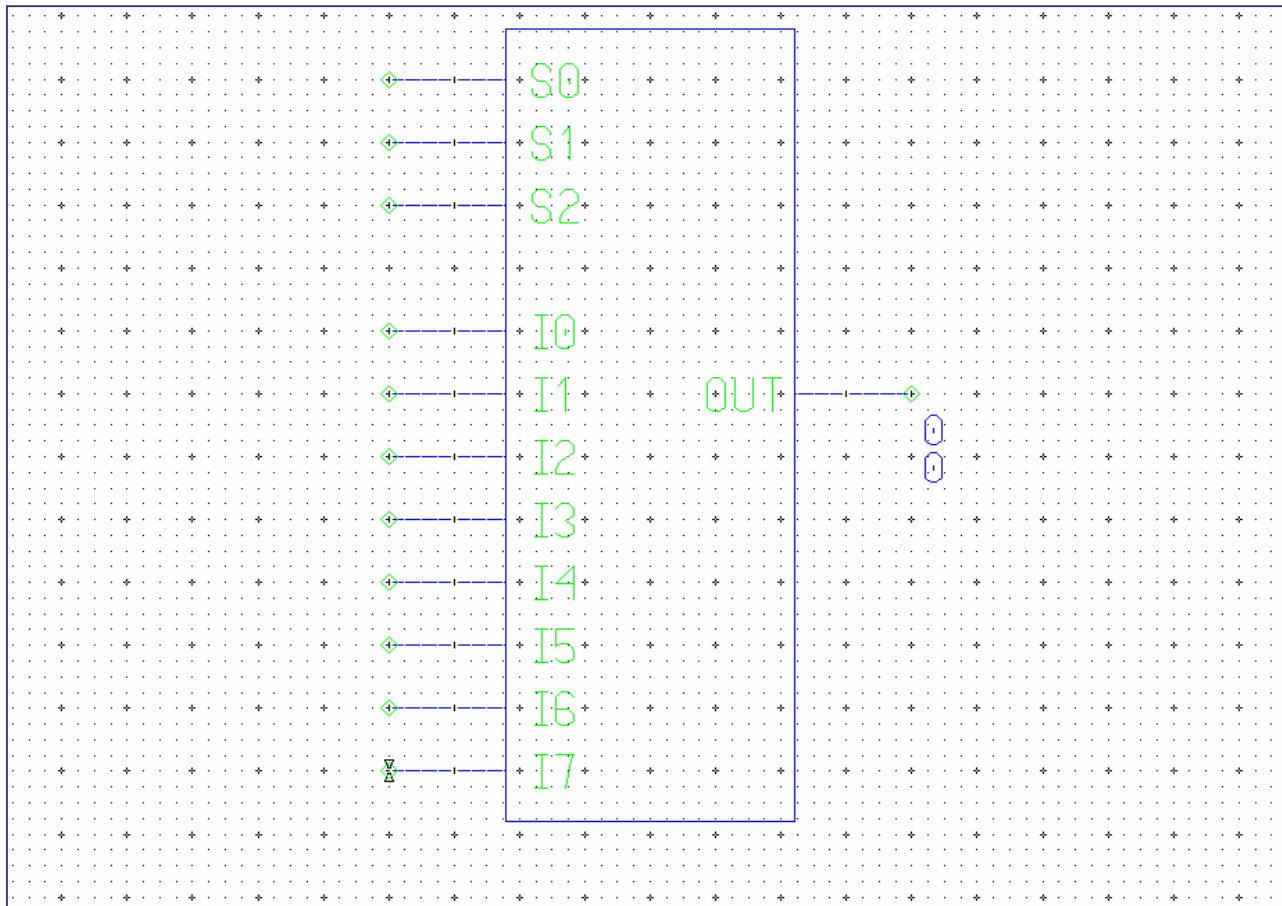

Figure 31: 8-TO-1 Multiplexor Modulus Schematics

8-TO-1 MULTIPLEXOR: Modulus Circuit

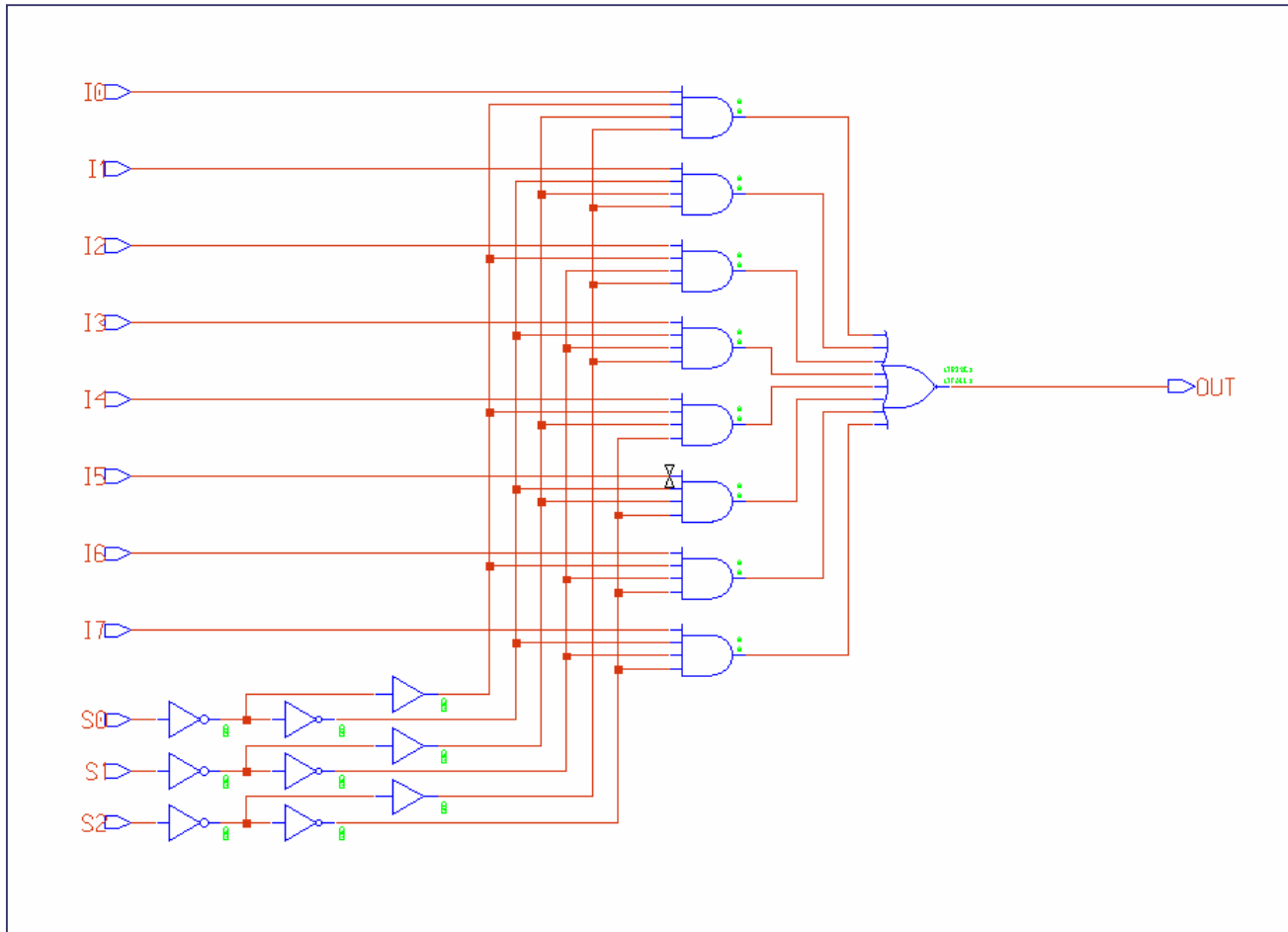

Figure 32: 8-TO-1 Multiplexor Modulus Circuit

SIMULATION STRATEGY

In order to conduct a time-efficient simulation of the “2181” ALU Project, and in order to guarantee a 100% error proof, each single module of the entire logic circuit implemented, simulated, and tested with Mentor Graphics running on a Sun Spark Station 5.

The simulation of each of the logic modules was conducted by varying their relative input, which was controlled by a clock function offered by Mentor Graphics itself. While keeping the duty cycle of the input signal constant, the period of the input signal was progressively doubled in order to cover all of the possible input signal combinations. Such a simulating method guaranteed a very rapid and global reading of the output of each of the logic modules.

The “2181” ALU Project was then assembled by connecting all of the logic modules through a battery of 8-to-1 MUX’s. The “2181” ALU Project was then simulated and tested by reading its output after varying the MUX controller (Input S.)

"2181" ALU PROJECT: Simulation 1/8

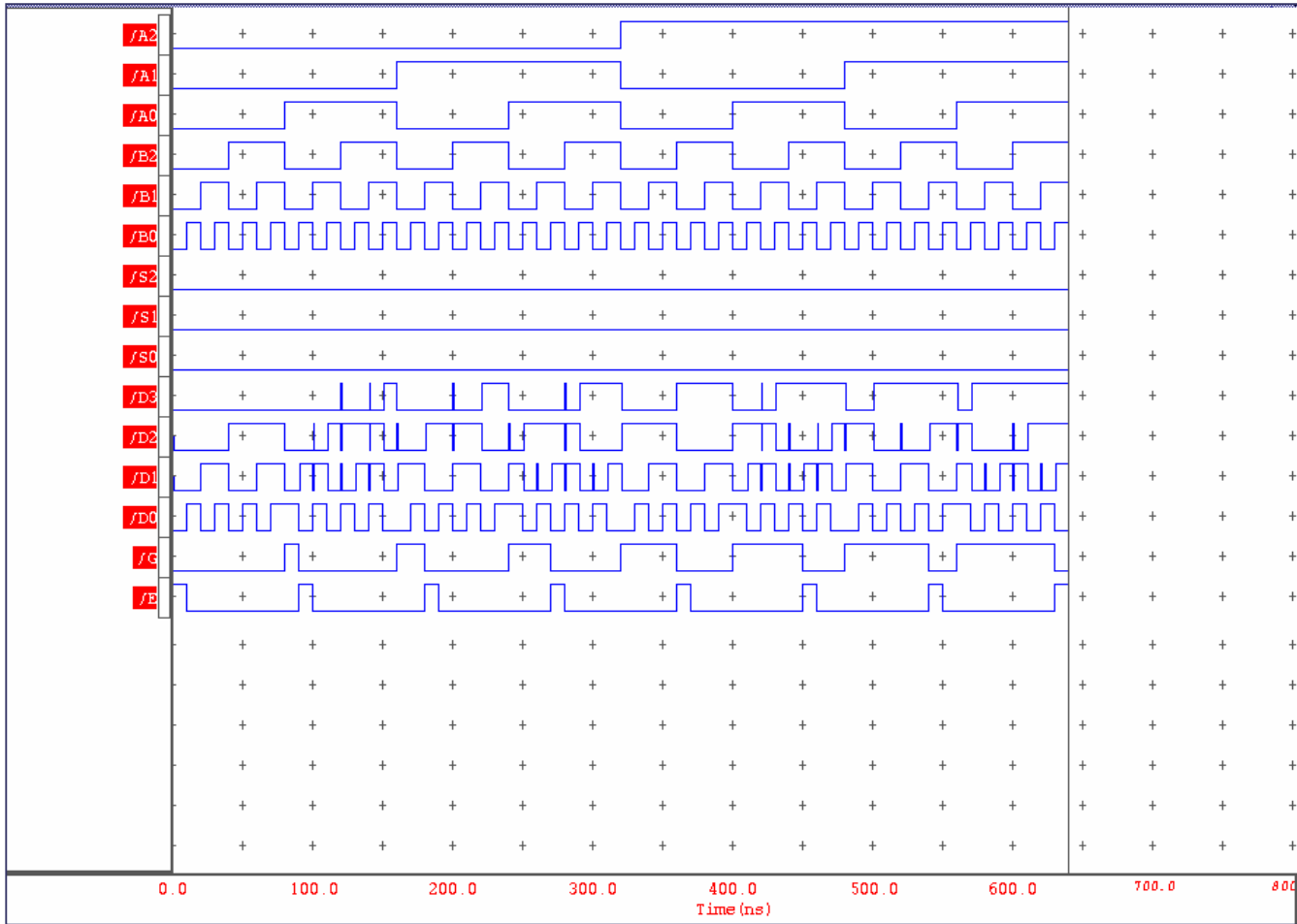

Figure 33: "2181" ALU PROJECT: Simulation 1/8

“2181” ALU PROJECT: Simulation 2/8

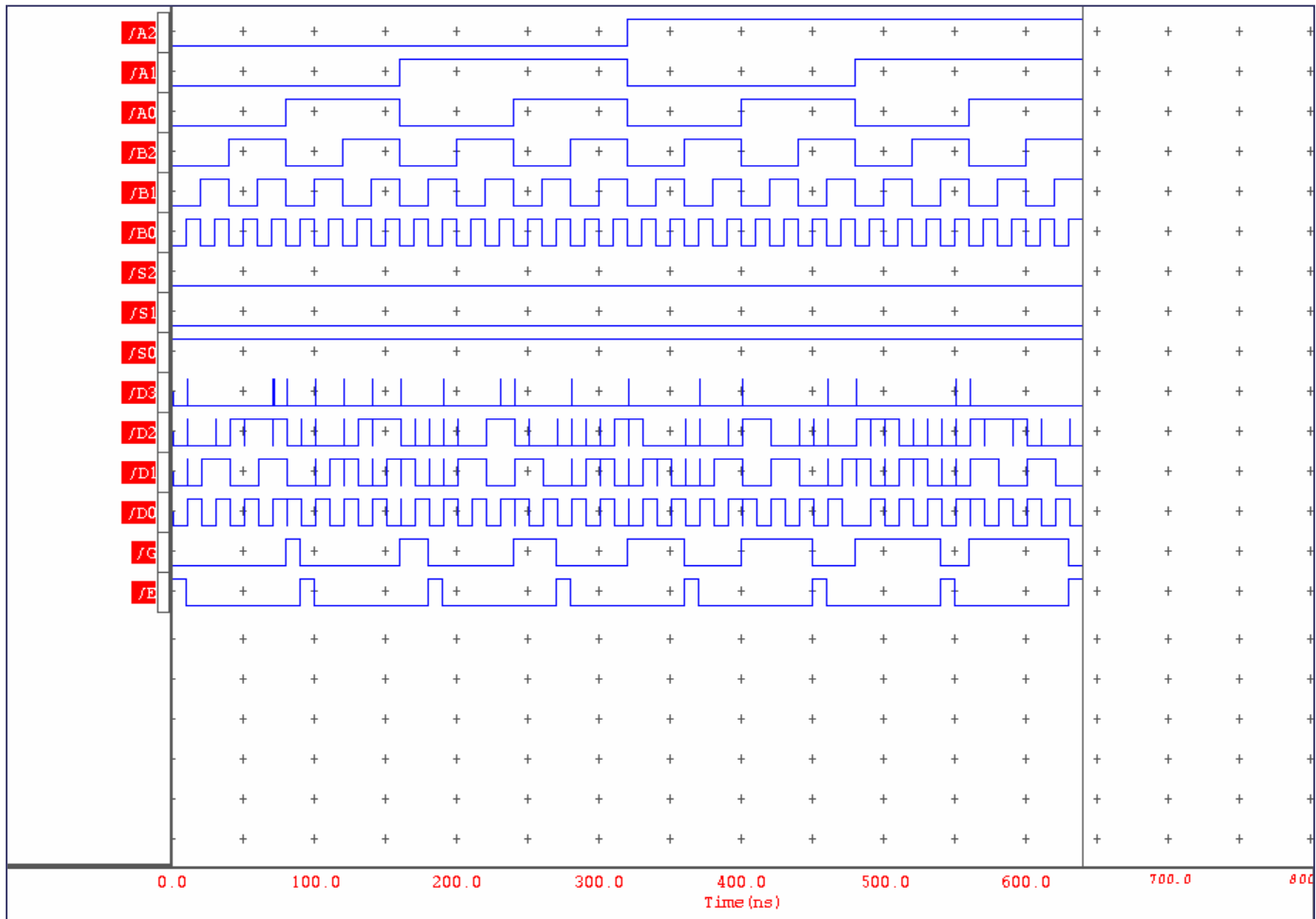

Figure 34: “2181” ALU PROJECT: Simulation 2/8

“2181” ALU PROJECT: Simulation 3/8

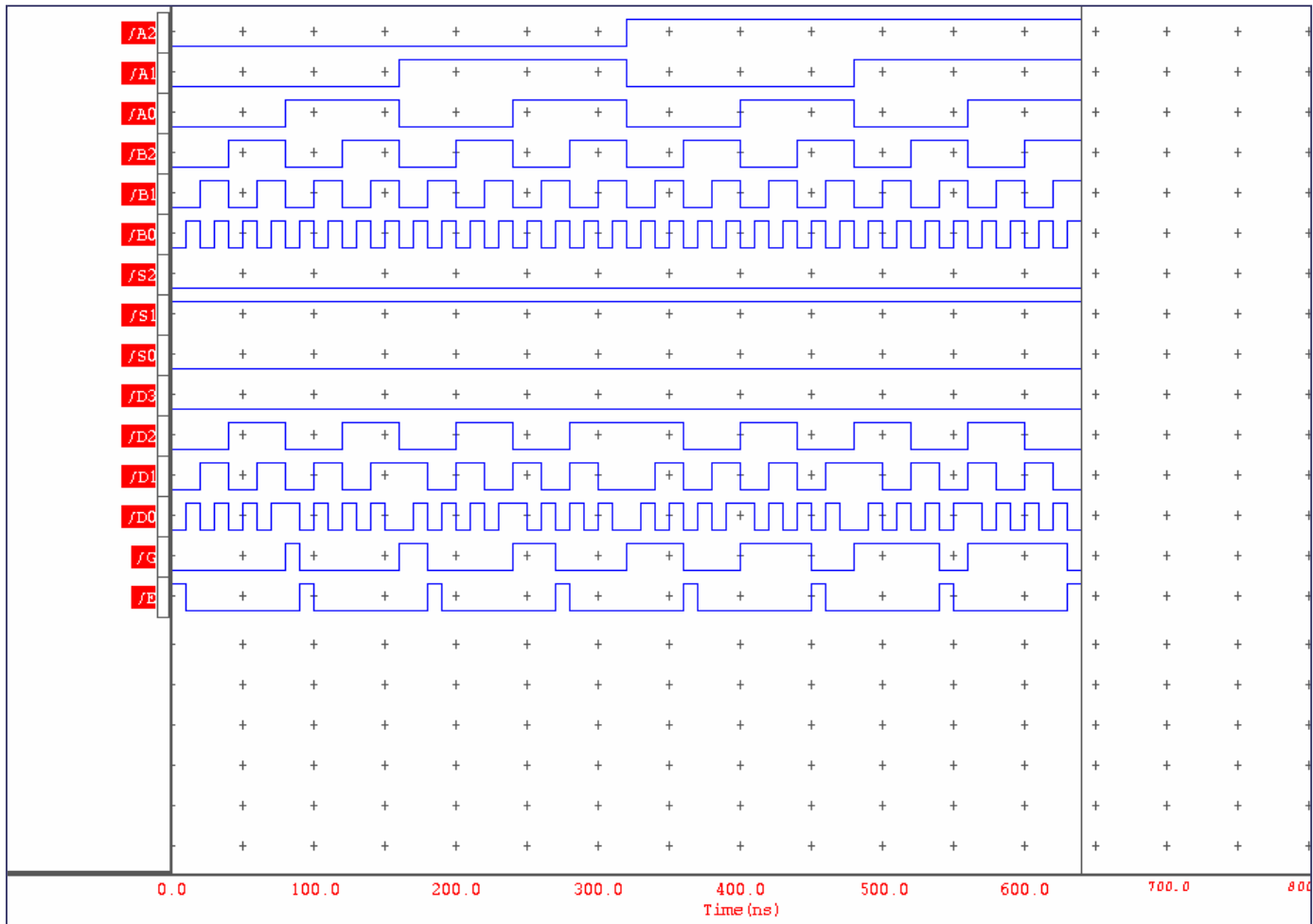

Figure 35: “2181” ALU PROJECT: Simulation 3/8

“2181” ALU PROJECT: Simulation 4/8

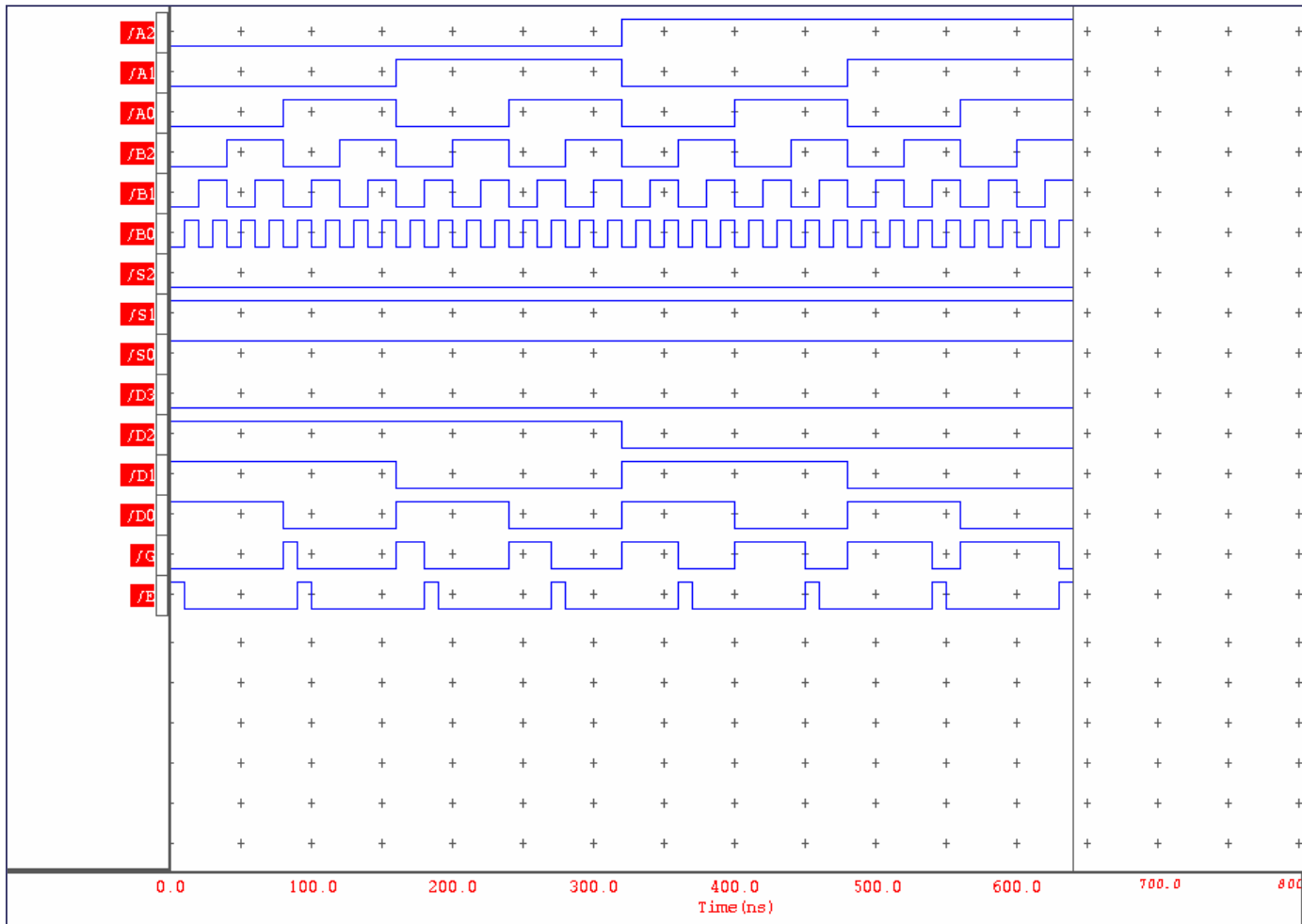

Figure 36: “2181” ALU PROJECT: Simulation 4/8

“2181” ALU PROJECT: Simulation 5/8

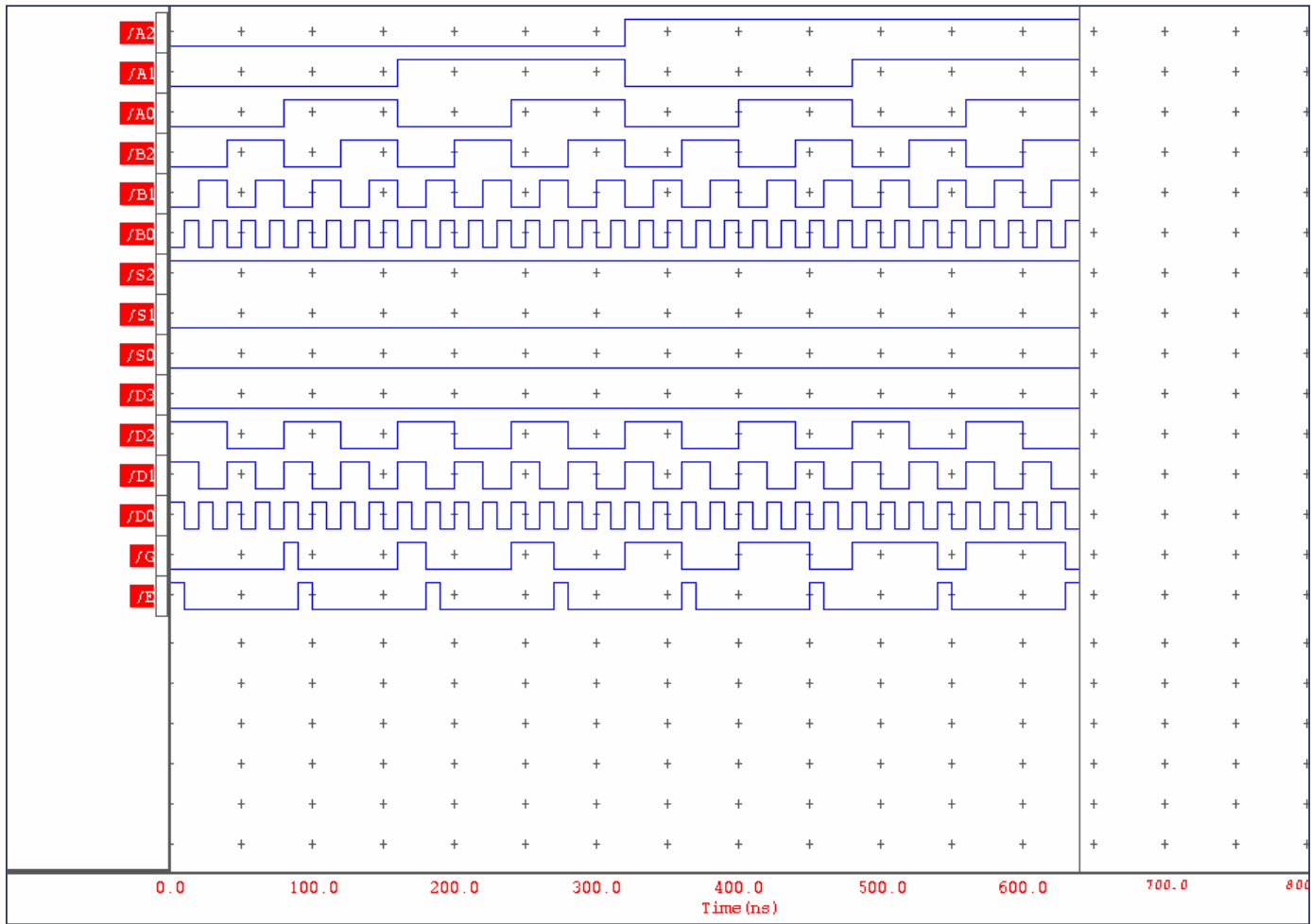

Figure 37: “2181” ALU PROJECT: Simulation 5/8

“2181” ALU PROJECT: Simulation 6/8

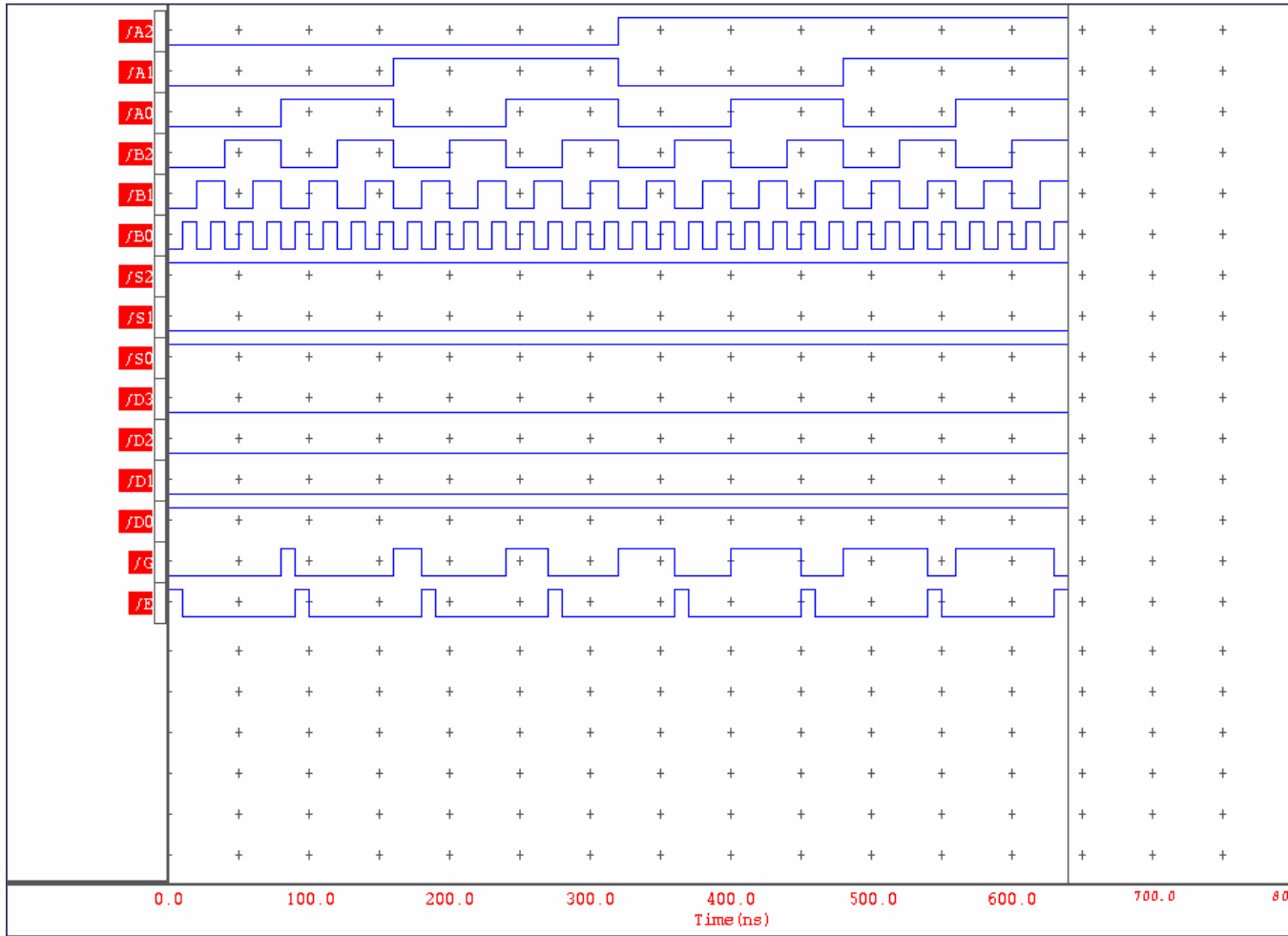

Figure 38: “2181” ALU PROJECT: Simulation 6/8

“2181” ALU PROJECT: Simulation 7/8

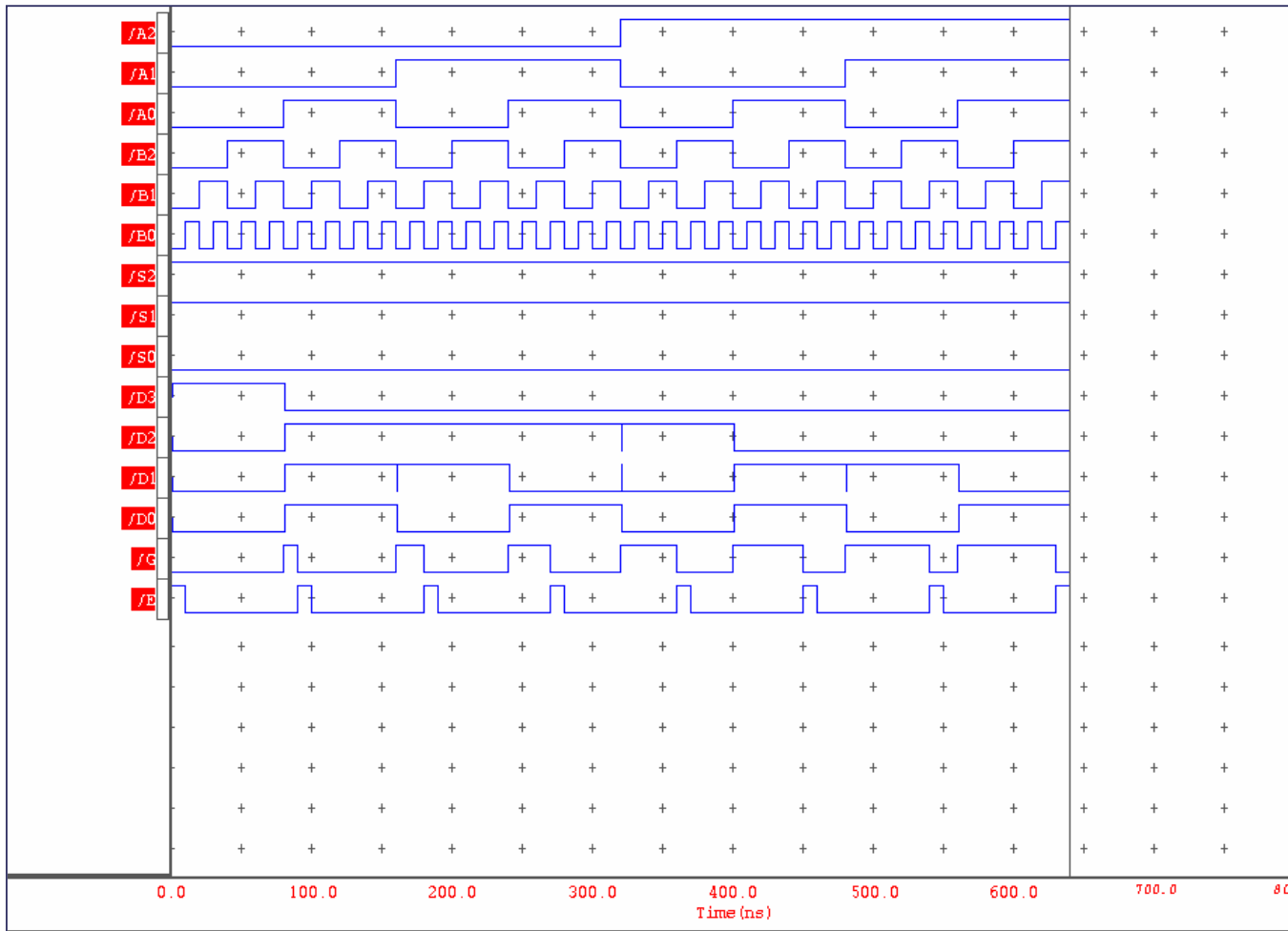

Figure 39: “2181” ALU PROJECT: Simulation 7/8

“2181” ALU PROJECT: Simulation 8/8

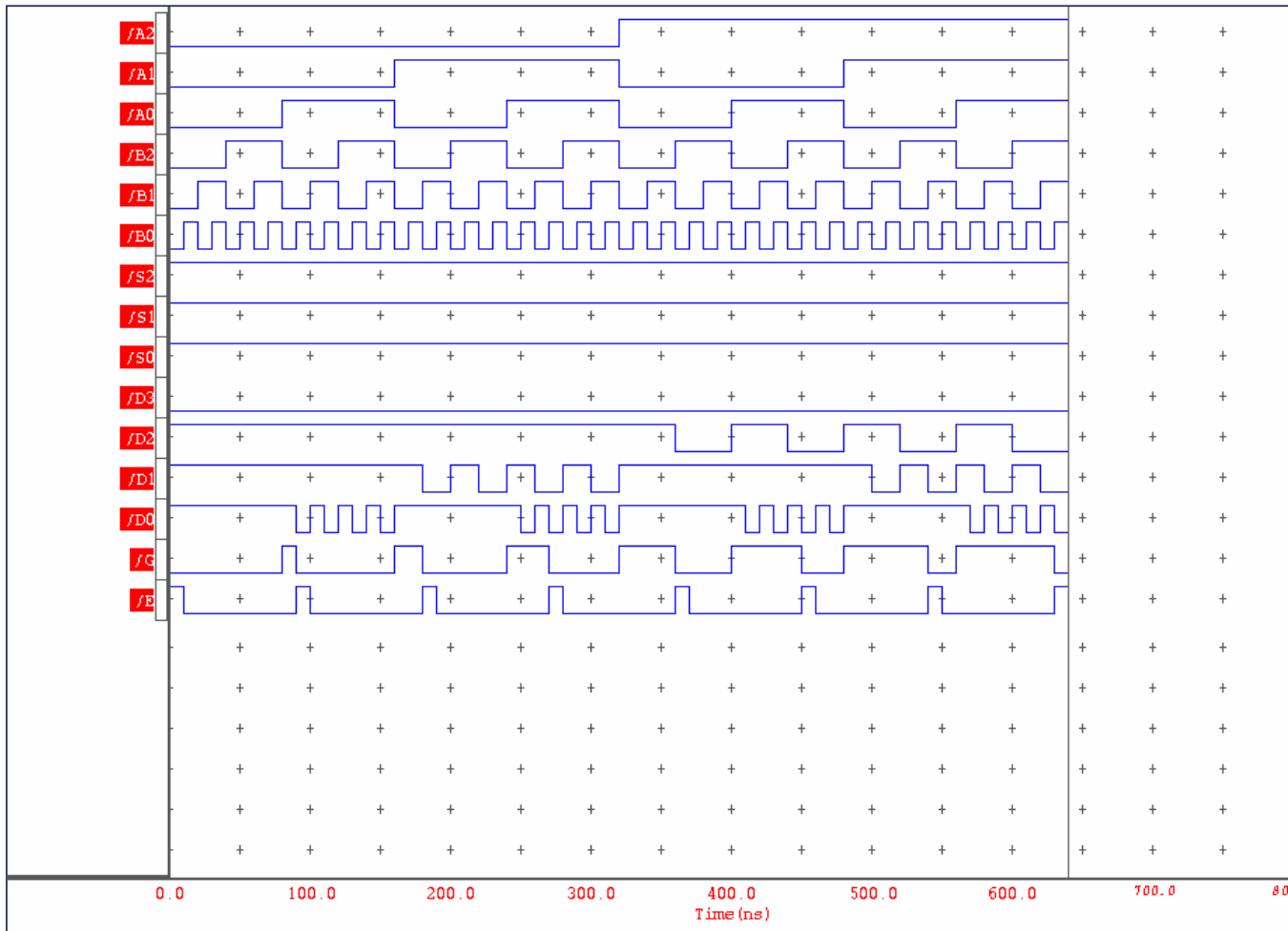

Figure 40: “2181” ALU PROJECT: Simulation 8/8

CONCLUSIONS

The results of the simulation matched the required criteria, and, in fact, the output of the “2181” ALU Project was consistent with the expected output; in other words, “2181” ALU Project worked properly.

All of the possible input and output combinations were simulated and tested, and no error was encountered; therefore the “2181” ALU Project is ready for a further implementation.